

1. 300L 3-Vessel Micro Brewhouse

300L 3-Vessel Brewhouse



Product Name	300L Brewhouse
Components	Left: Hot Liquor Tank
	Right: Mash+ Lauter Tank
	Middle: Kettle + Whirlpool Tank
Dimension	2760mm(L)*1910mm(W)*1532mm(H)
Weight	700kg
Installation Method	Assembled ready to use
Heating Method	Build-in Electric Elements
Consuming power	50 kw
Operability	Easy
Control System	PID Control
Application	Lager, Ale, IPA, Creative Craft Beer

Production Technology

1. Inner-Jacket (SUS304), TH=3.0mm, pickling&passivating treated;
2. External-Jacket(SUS 304), TH=2.0mm, ink wires drawing plate
3. Atmosphere manual open top lid, TH=3.0mm
4. Tanks' Insulation layer: PU-thickness= 40mm.
5. 100% high precision TIG welded joints
6. complete skid-mounted structure with leveling pad
7. Apply for voltage: 415V, 50HZ, 3 Phases
8. Three year warranty for the main products, one year for fittings

1. 300L 3-Vessel Micro Brewhouse

1-1 Mash/Lauter Tank

1. Effective volume=300L, max volume=380L

2. Atmospheric manual open top lid

3. Tri-clamp Spary Ring Tube

4. Wort backflow pipeline equip with Sight glass

5. Removable false bottom

6. Grain out door & Grain Chute & Manual rake

7. Temperature Probe&PT-100

8. with 3T/H Wort pump, 0.75kw, VFD Control by PID control panel

9. Tri-clamp CIP Ball on the lid

10. Temperature Probe & PT-100

11. with level mark inside of tank

1-2 Kettle/Whirlpool Tank

1. Effective volume=300L, max volume=500L

2. Atmospheric manual open top lid

3. 12kw electric element x 2 pcs

4. Tangent whirlpool inlet

5. Add rotary device on the bottom side of tank body (2nd outlet)

6. with condensing pipe on top of lid

7. Tri-clamp CIP Ball on the lid

8. Temperature Probe & PT-100

9. Pipeline shares the same pump with mash/latuer tank

10. with level mark inside of tank

1-3 Hot Water Tank

1. Effective volume=300L, max volume=380L

2. Flange connected dome head, with atmospheric manhole, and condensing pipe, and CIP ball build inside

3. 12kw electric element x 2 pcs

4. With 3T/H Hot water pump, 0.75kw

5. Temperature Probe&PT-100

6. with level mark inside of tank

1. 300L 3-Vessel Micro Brewhouse

1-4 Knocking Out Fittings

1. High precision hops filter, equipped in pipeline before PHE
2. 3m² double stage plate heat exchanger (Tap water | Hot wort | glycol water)
3. Temperature Gauge after PHE
4. Tap water outlet from the PHE to be able backflow into Hot water tank
5. Sight glass equip on pipeline after heat exchanger
6. Oxygenation device before wort knocking out port
7. Butterfly valve equip on the end of pipeline, to be able to clamp hoses

1-5 PID Control System

1. SUS 304 Material cabinet
2. Temperature indicator & heating elements on/off control of mash/lauter tun, kettle/whirlpool tank, hot water tank
3. Wort Pump VFD Speed control
4. Hot water pump on/off control
5. With high quality electric components, Omron, Schneider brand
6. CE, ISO Certificated

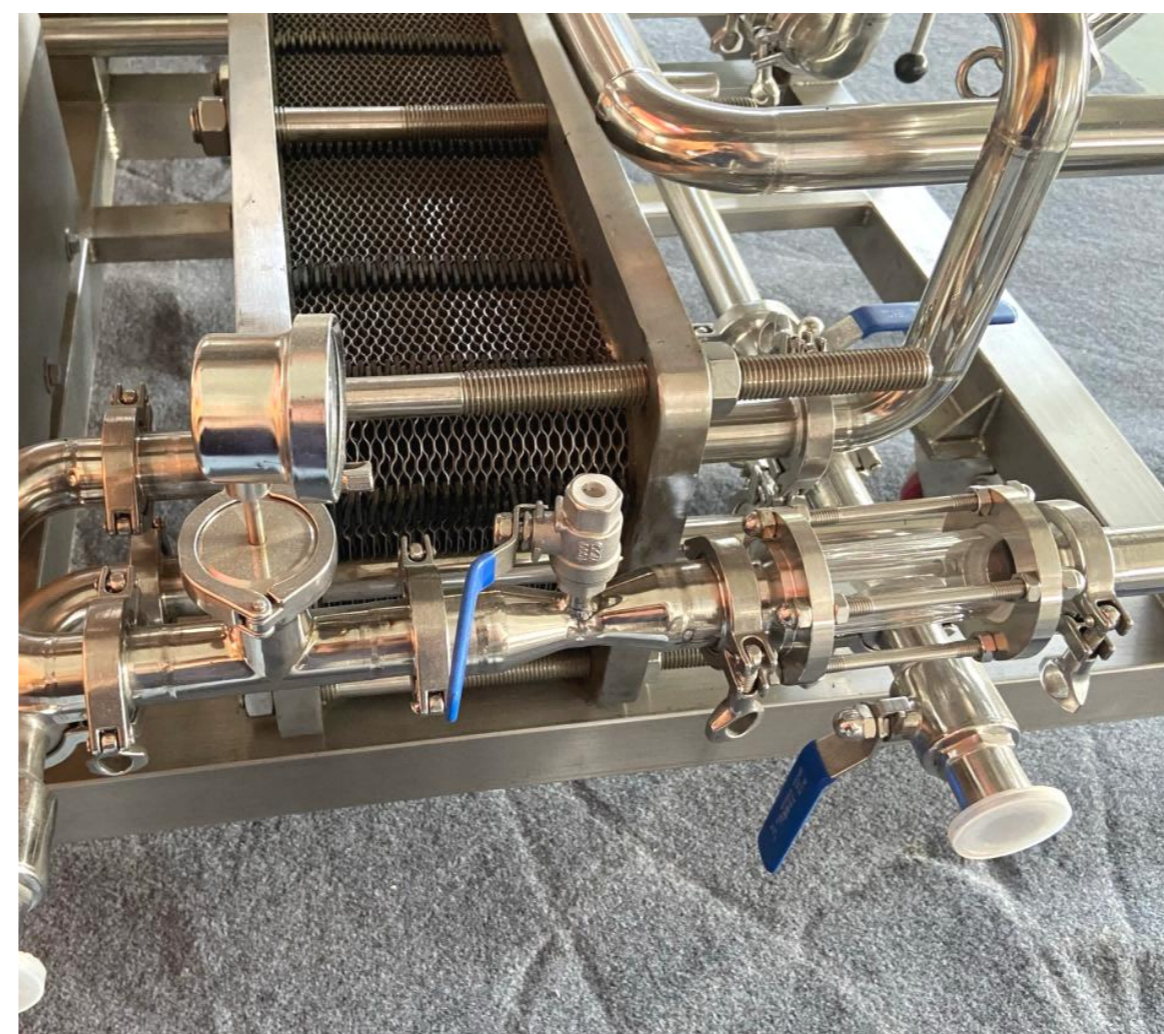

2D Drawing

Mark	Name	Spec.	Connection
a	top lid	Manual	TIG Weld, quick open
b	Vinesse door	430*330mm	weld
c	CIP Ball	1.5"	tri-clover
d	Sight glass & back flow	1.5"	tri-clover
e	flange dish head & manhole	980mm	Flange (with gasket)
f	heating elements	16kw x 2, 1.5"	tri-clover
g	Hops filter	mesh	tri-clover
h	Temperature probe	8mm	screw
i	Plate heat exchanger	3m2, 2-stages	tri-clover
j	Oxygenation fittings	1.5"	tri-clover
k	PID Control panel	wired	pre-installed

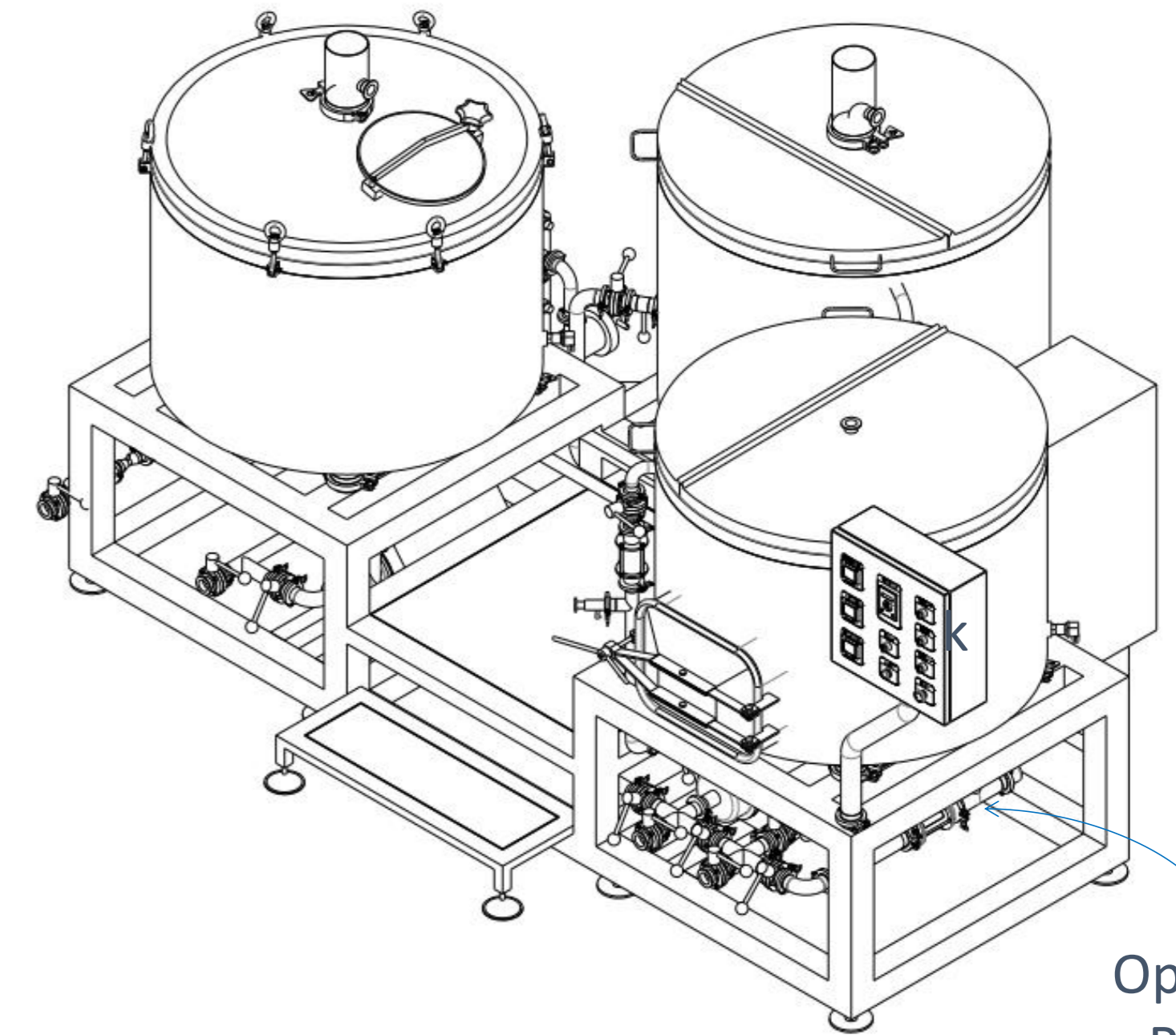

Optional:
RIMS
connection

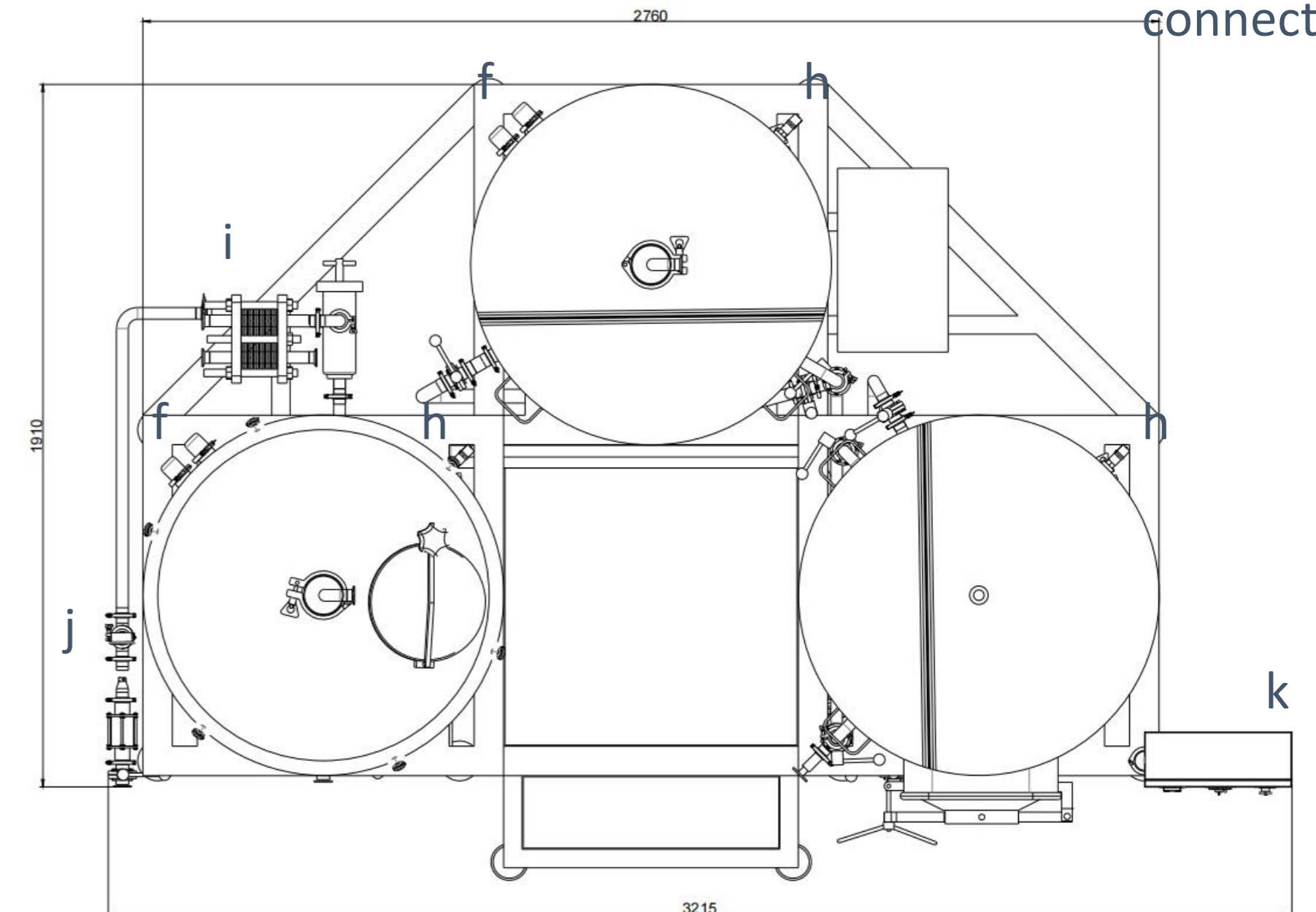
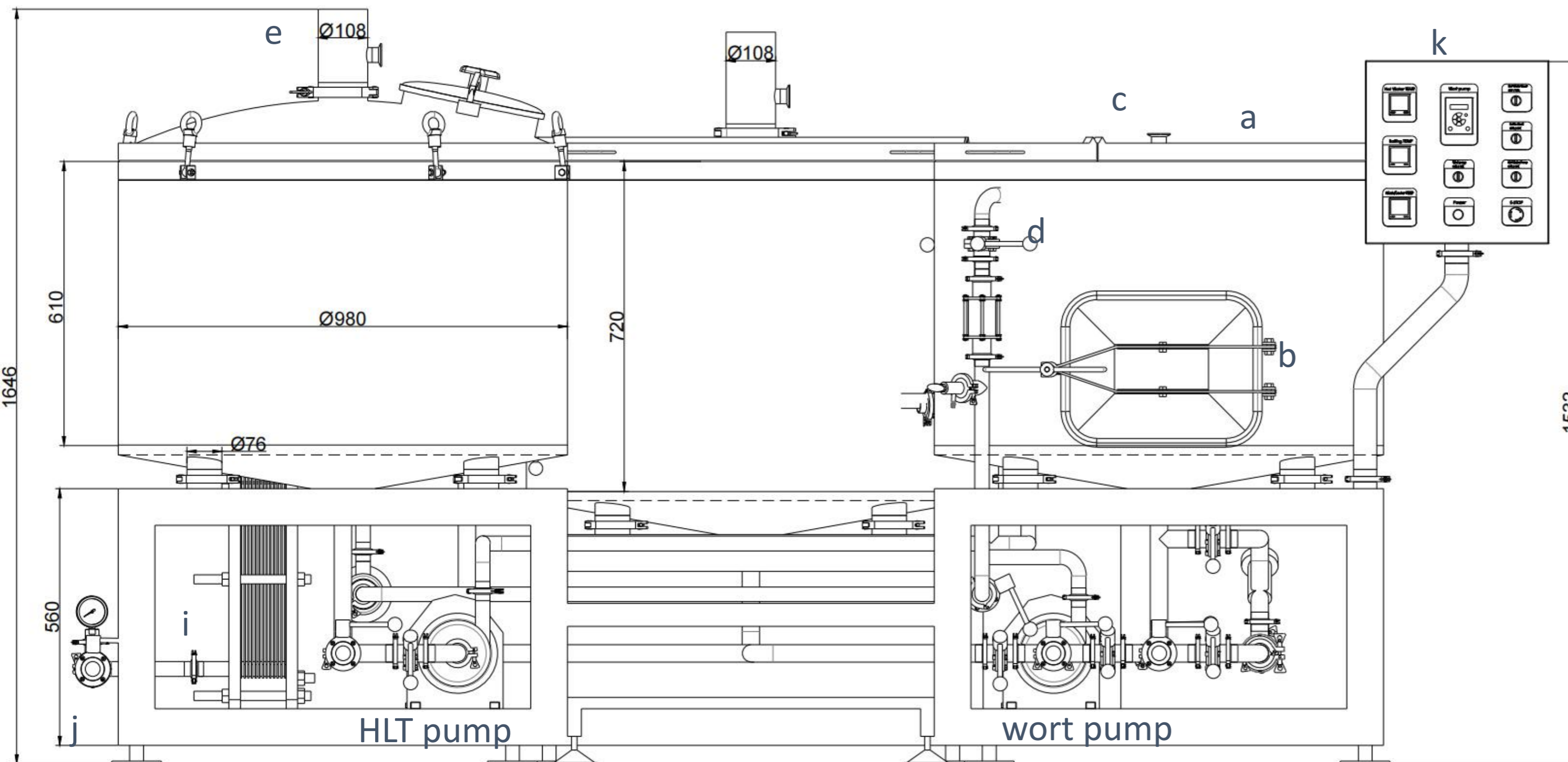

Top View

Job View

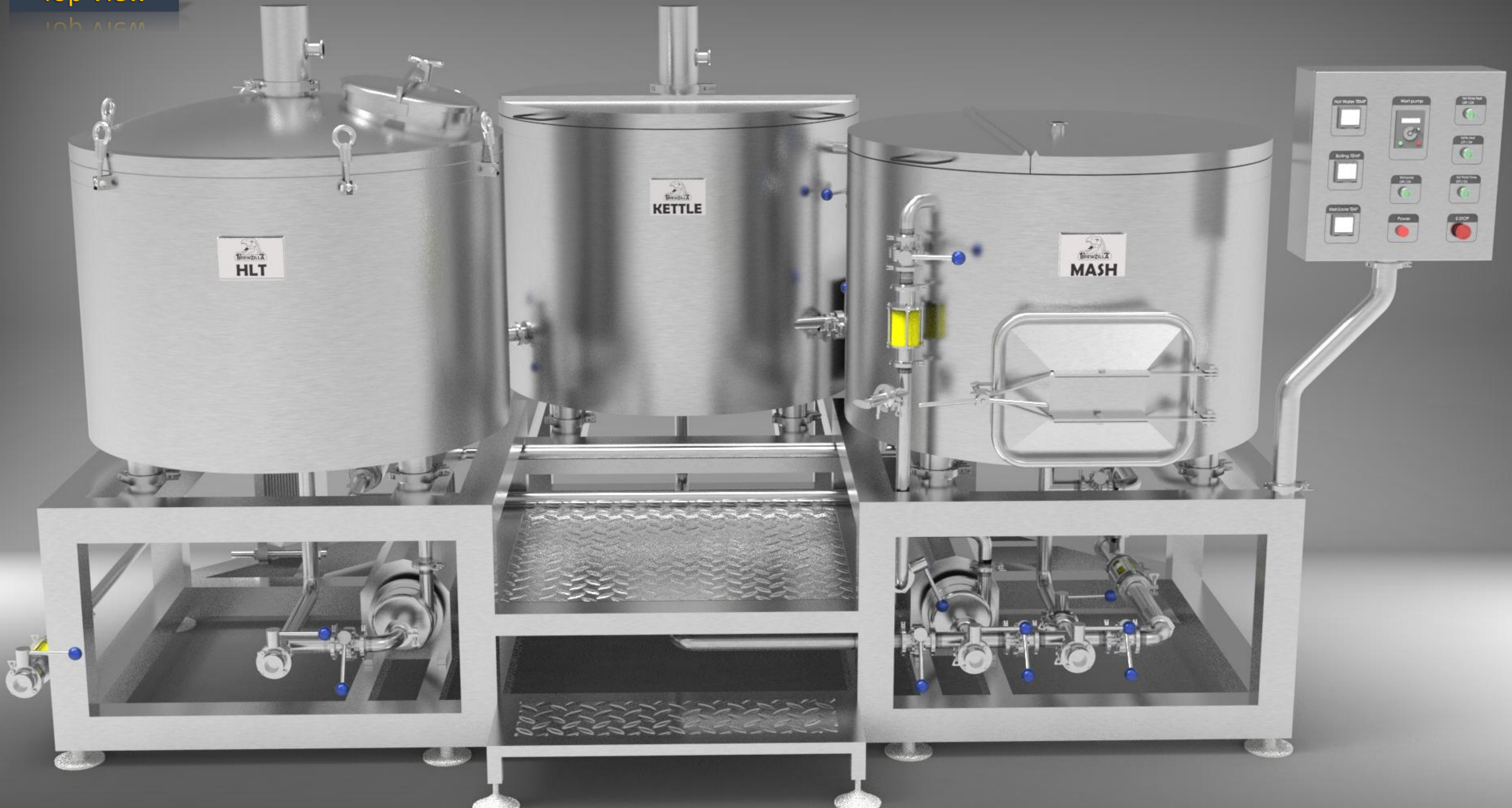

Left View

EGC A16M



Right View

WIBU AISM



Back View

BACK VIEW



Back View

BACK VIEW



Pipeline
View
AIGM

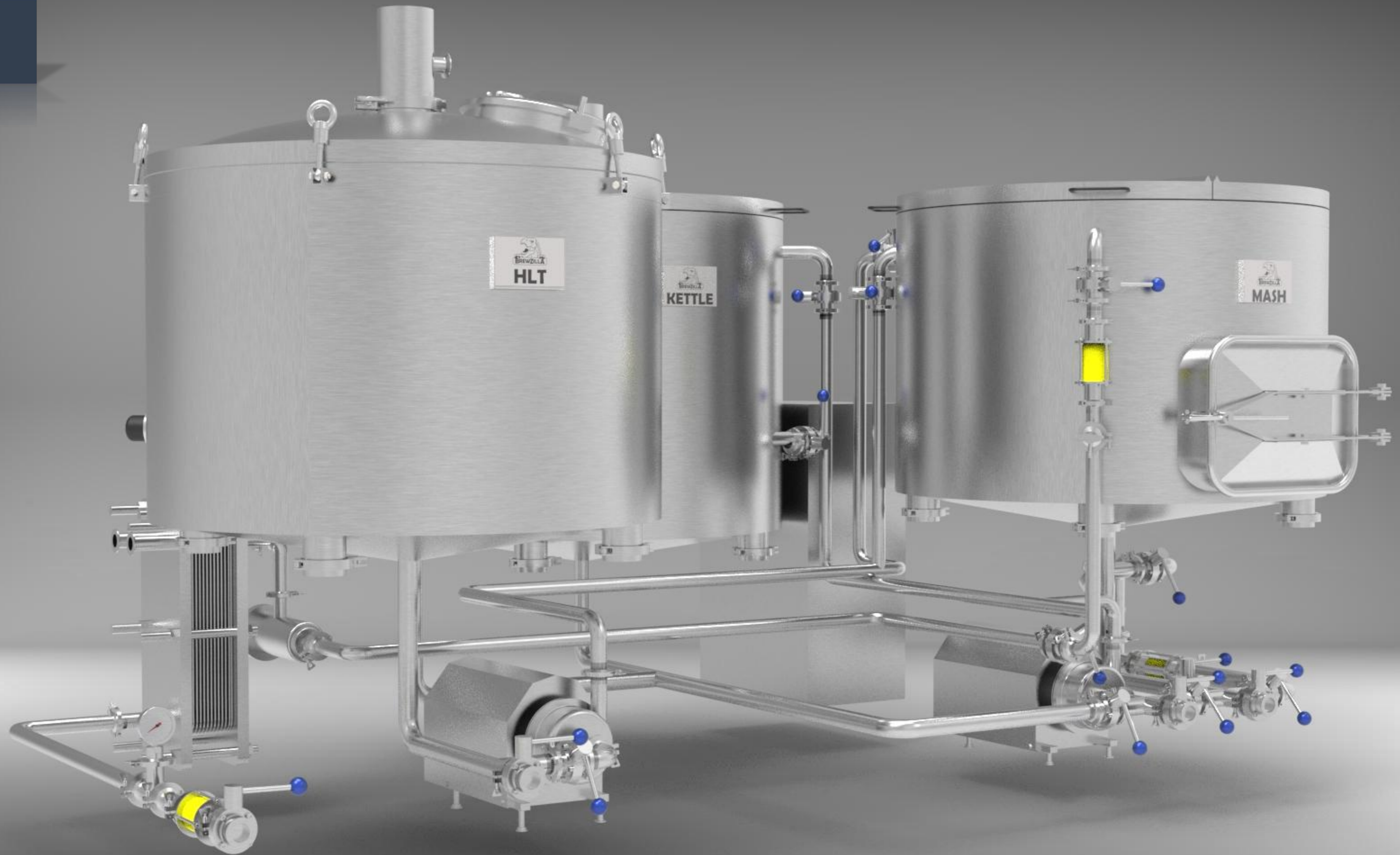

Pipeline
View

▲IGM



Pipeline
View

▲IGM

