



**Crystal8 – 5.2 kW  
Industrial Glycol Chiller  
KL36252**

**Owner's Manual**

**Please read this owner's  
Manual carefully before  
operating the unit.**

**KegLand Distribution PTY LTD**



## Table of Contents

Specifications <sup>[2]</sup> .....	3
Refrigeration Principle .....	5
Installation .....	6
Positioning .....	6
Cooling Water / Glycol Requirements .....	7
Hosing/Tubing.....	8
Adding Water to the Water Tank.....	8
Operation and Parameter Adjustment .....	9
Control Panel.....	9
Main Interface.....	9
Changing Set Temperature .....	9
Alarm Interface .....	10
Function Menu.....	10
Parameter Adjustment .....	11
Parameters.....	11
Fault Code Table .....	12
Control Logic .....	13
Electrical Diagram .....	14
Troubleshooting.....	15
Maintenance .....	16
Service and Warranty.....	17

## Specifications <sup>[2]</sup>

Model		5.2 kW Industrial Glycol Chiller		
Cooling Capacity <sup>[1]</sup>	kW	5.2		
	kcal/h	4.5 x 10 <sup>3</sup>		
Power Source	V/ph/Hz	220/1/50		
Gross Power	kW	1.2		
Rated Current	A	5.9		
Compressor	Type	Rotor Type		
	Power	kW	1.6	
Condenser	Type	Efficient inner fin coil		
	Fan	Axial Flow		
Evaporator	Type	Shell and tube type		
	Tank Volume	L	35	
	Pipe Size	DN	20	
	Water Flow	m <sup>3</sup> /h	0.89	
		L/min	14.8	
Pump	Type	Stainless steel centrifugal		
	Power	kW	0.37	
	Head	m	26	
Refrigerant	Type	R22/R407C		
	Throttling Type	Expansion valve		
Protector		Pressure. Overload, Delay, Over-temperature, Flow		
Noise Level	dB(A)	58		
Unit Weight	kg	108		
Dimensions	L	mm	600	
	W	mm	600	
	H	mm	1160	

<sup>[1]</sup> The above cooling capacity is based on the ambient temperature 35°C and outlet temperature 7°C

<sup>[2]</sup> Design and specification are subject to change without prior notice

# Crystal8 – 5.2 kW Industrial Glycol Chiller

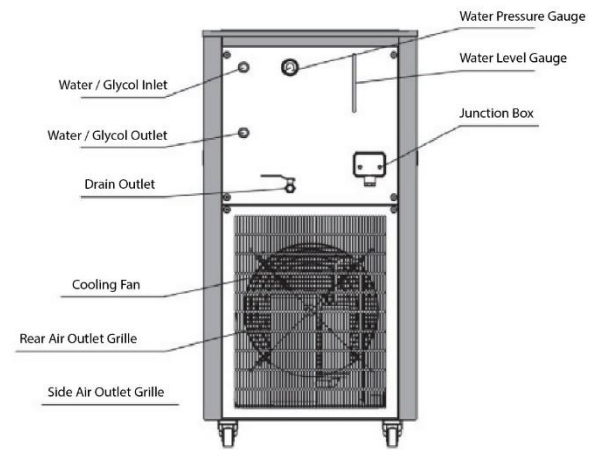
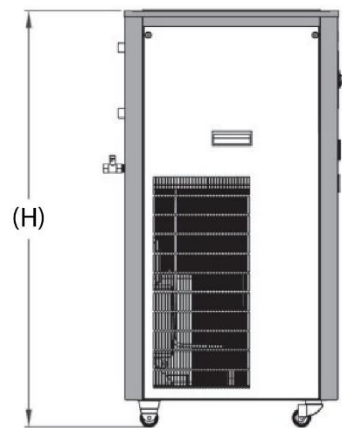
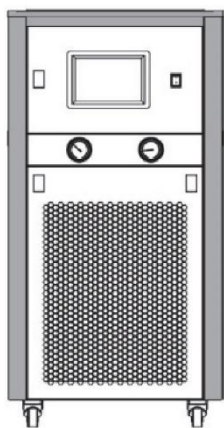

[

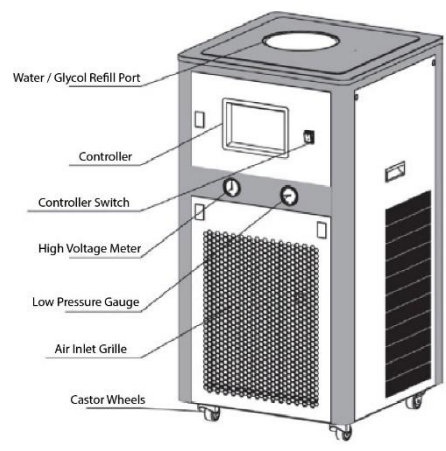
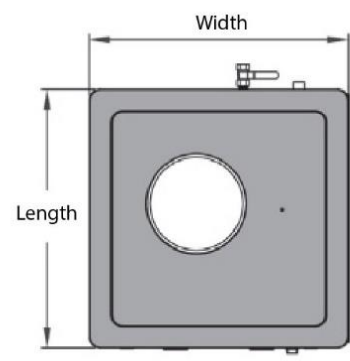

## Refrigeration Principle

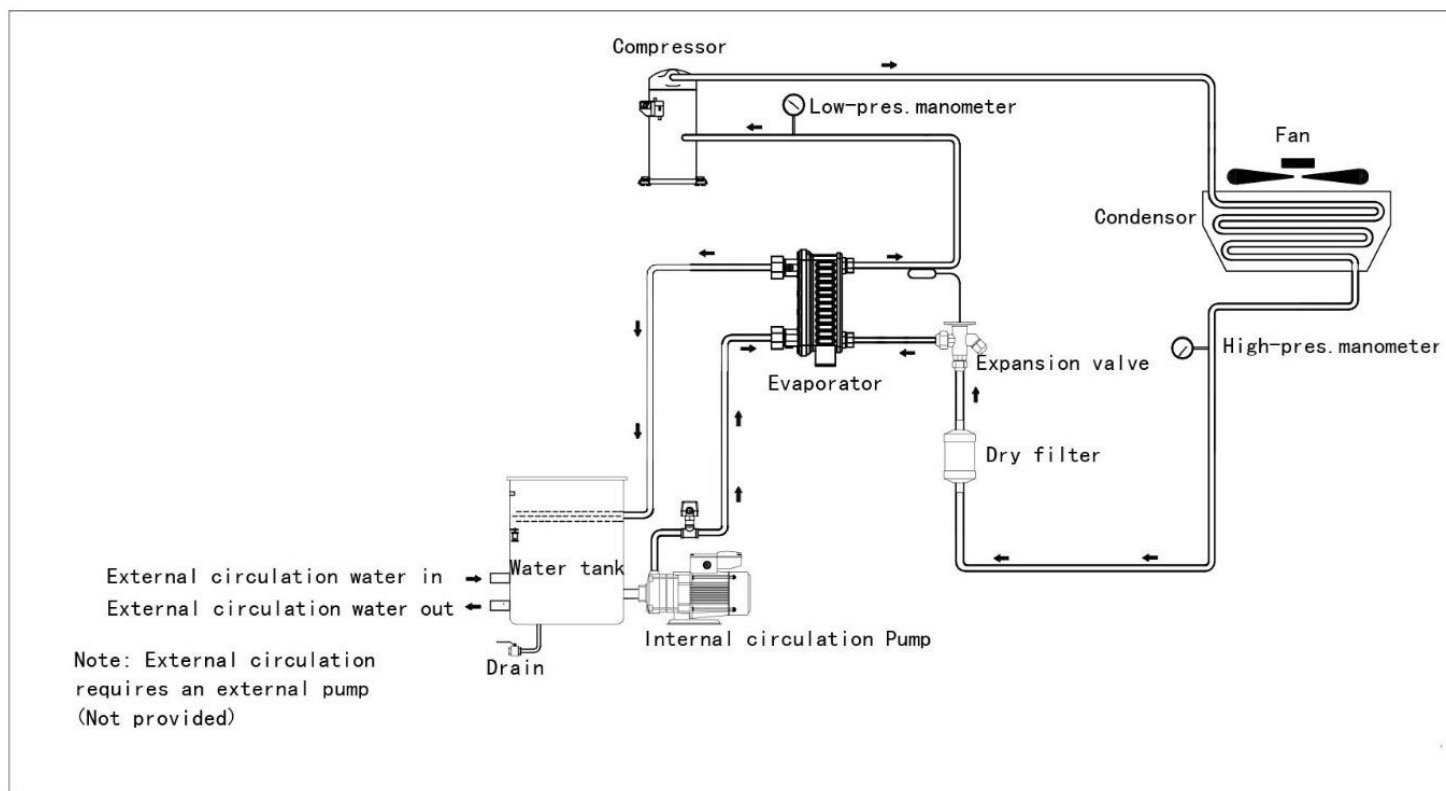

The Crystal8 industrial chiller uses a freon forced cooling method in which the glycol solution is constantly circulated through the plate heat exchanger and evaporator using the in-built pump. The plate heat exchanger takes advantage of shunt and counter current methods to maximise heat exchange efficiency.

When the glycol temperature which is returned from the into the chiller measures higher than the set value on the chillers temperature controller the refrigeration system will begin circulating liquid fluorine into the plate heat exchanger to allow for heat exchange. This will drop the temperature of the circulating glycol solution which will mix with the solution in the water tank to ensure the temperature in the water tank is controlled within the specific set range.

When the return water temperature is lower than or equal to the set value, the refrigeration system will stop recirculating into the heat exchanger until the return water temperature is again above the set value on the temperature controller.

This system will keep your circulating coolant water at the specified set value and hence it may require the use of external filters, pressure relays and water flow switches according to the actual desired use of the chiller.

## Installation

### Positioning

1. Installation environment: the chiller should be installed in a well-ventilated and clean air environment, clear of any corrosive gases, flammable and explosive goods and away from high temperatures and strong electromagnetic interference.
2. Install close to the power supply and water source
3. Install in area with temperatures between 0 - 40°C, relative humidity  $\leq$  90% and altitude  $\leq$  3000m.
4. Direct sunlight on the chiller should be avoided. If installed outdoors appropriate rain protection measures must be taken (especially for electrical boxes and operating panels).
5. Installation foundation: the foundation which the chiller is installed on should be able to fully withstand the total weight of the unit and the forces transmitted by its work. The inclination of the foundation should not be greater than 5 degrees.
6. Installation principles: ensure that there is a clearance of at least 400mm around the air inlets and outlets and 300mm between the top of the unit and any overhead objects.

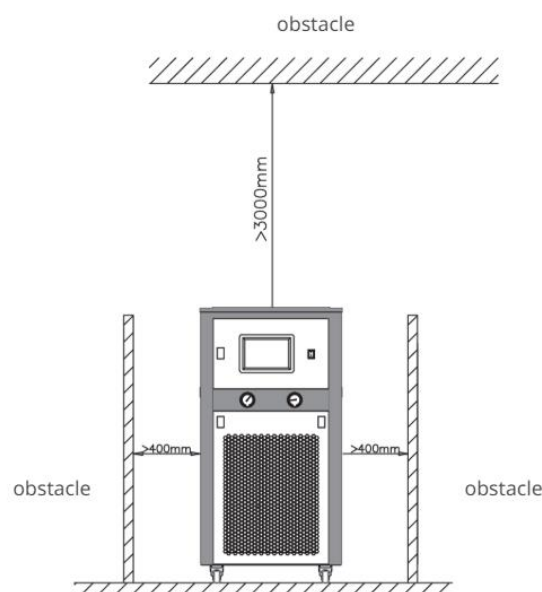
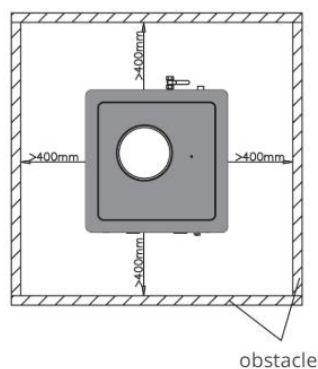

7. Lifting requirements: The chiller can be moved short distances on flat ground using its castor wheels. If moving a larger distance or on uneven ground then lift using a forklift. When lifting the chiller to install it in its final position, it should be protected from external force impact or excessive bumps and damage. It is strictly prohibited to skew or invert the chiller. During lifting the chiller should be supported at its centre of gravity and sharp increases or decreases in height are to be avoided.

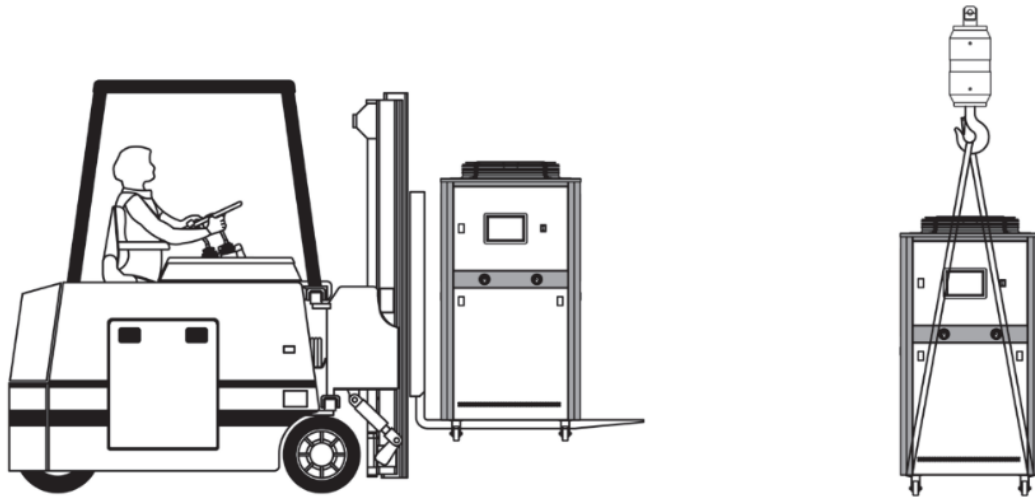

### Cooling Water / Glycol Requirements

1. The cooling medium must be softened water such as softened tap water, pure water, distilled water or high-purity water. If hard water is used then this can result in mineral and limescale build up that can affect the performance of the unit.
2. Do not use ethylene glycol as an antifreeze as this is weakly acidic that will corrode components with long term use and can result in serious damage to the unit. Only use propylene glycol concentration  $\leq 20\%$  concentration.
3. Approved bactericides or preservatives can be used with the system to reduce mold growth.

## Hosing/Tubing

1. Pipe diameter requirements: The inside diameter of all hosing and tubing must be strictly in accordance with the internal diameter of the chiller water in/out pipe. Do not reduce the pipe diameter below the size of the inlet/outlet on the chiller.
2. A water filter must be installed at the water / glycol inlet to prevent any dirt in the system from blocking the heat exchanger.
3. Distance from the vessel: the inlet of the chiller should be as close to the vessel as possible, and the length of any elbows and pipes should be as low as possible to reduce pressure drop.
4. Hosing requirements: It is recommended to use steel wire reinforced hose for the inlet and outlet pipe or install shock-absorbing hose for outlet and inlet of the chiller.
5. Drain the water / glycol from the system when not used for long periods of time in winter to prevent water from freezing in the heat exchanger and water pump causing damage to the unit if the ambient temperature drops below 0°C.
6. After installing all pipework, hosing and tubing make sure to perform a hydraulic leak test on the system.
7. During operation, cooling water / glycol should be regularly sampled and analysed to ensure that it is in good condition and the glycol concentration is still correct.
8. If the water inlet and outlet pipes are more than 1 meter higher than the water level of the chiller then a check valve should be installed at the water outlet and water inlet to prevent backflow into the tank and overflow.

## Adding Water to the Water Tank

1. Ensure the water has been softened to prevent limescale build up.
2. Open the water / glycol refill (observation) port at the top of the unit and add water until the heat exchanger is fully submerged below the surface of the water.
3. After adding water for the first time or changing the water in the water tank there will be air in the pipes. Start the water pump to circulate the water in the system. One or several flow failure alarms may occur. Reset the fault and continue to start the water pump until the air is exhausted and the faults no longer appear.





## Operation and Parameter Adjustment

### Control Panel

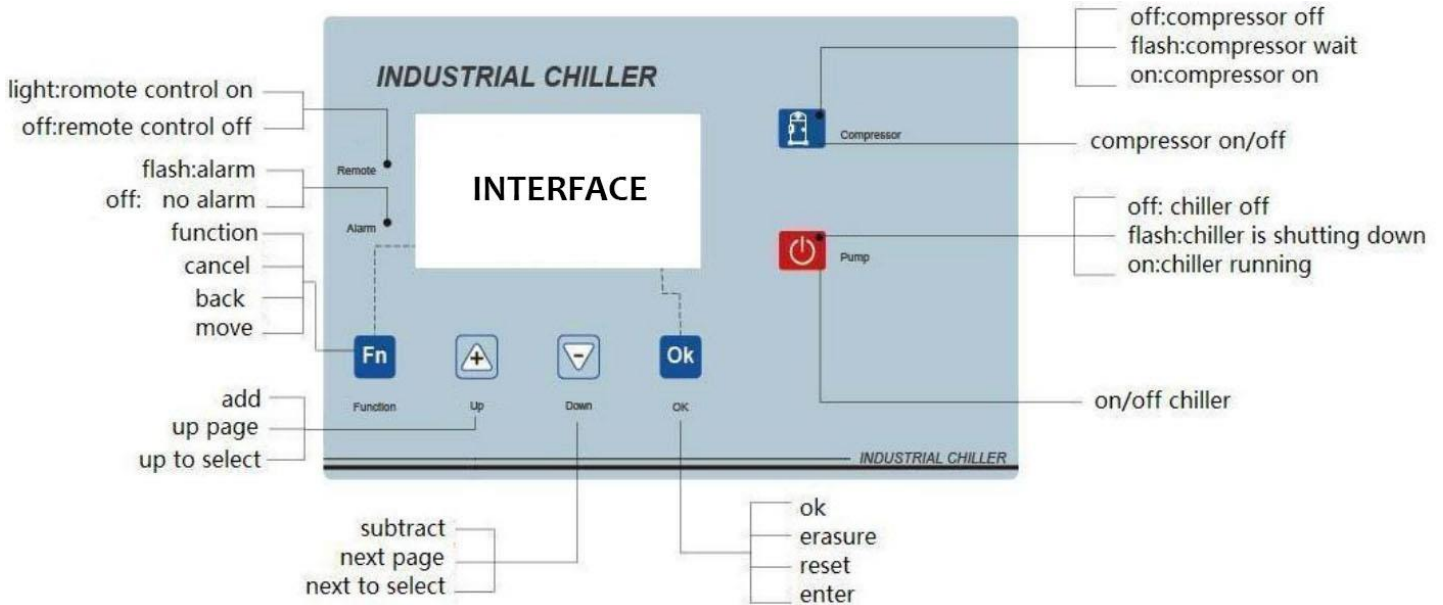

### Main Interface

During normal operation the following will be displayed on the interface.

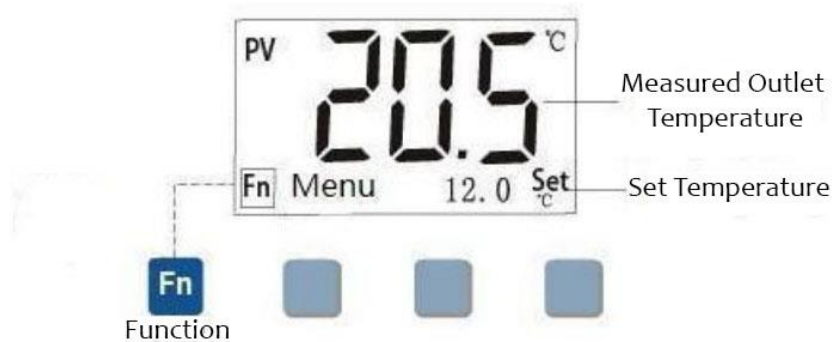

### Changing Set Temperature



To change the set temperature of the chiller, while on the main interface press the “Up” or “Down” arrow to change the displayed set temperature.

### Alarm Interface

When an alarm occurs, the following interface will be displayed automatically:

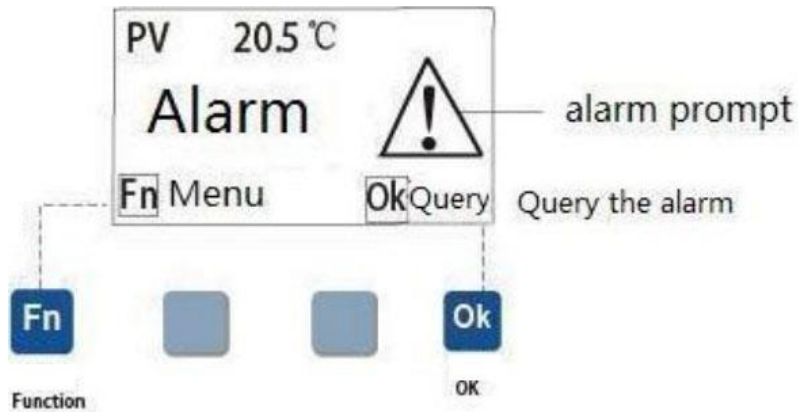

To determine the reason for the alarm press “Ok” to query the alarm. Then press “Ok” to reset the control panel.

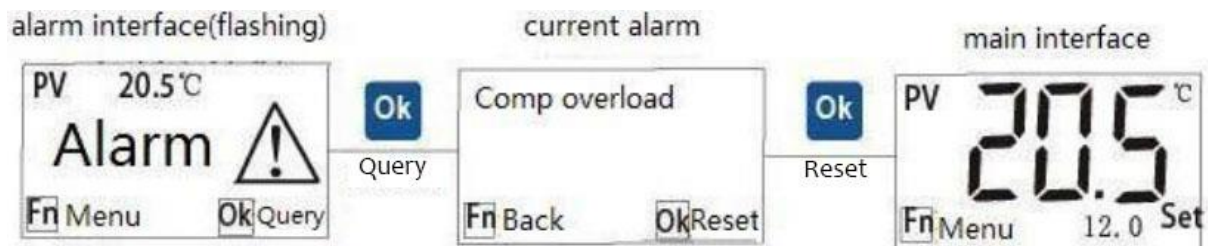

### Function Menu

Press Fn to enter the Function Menu. This menu will display the following five items:

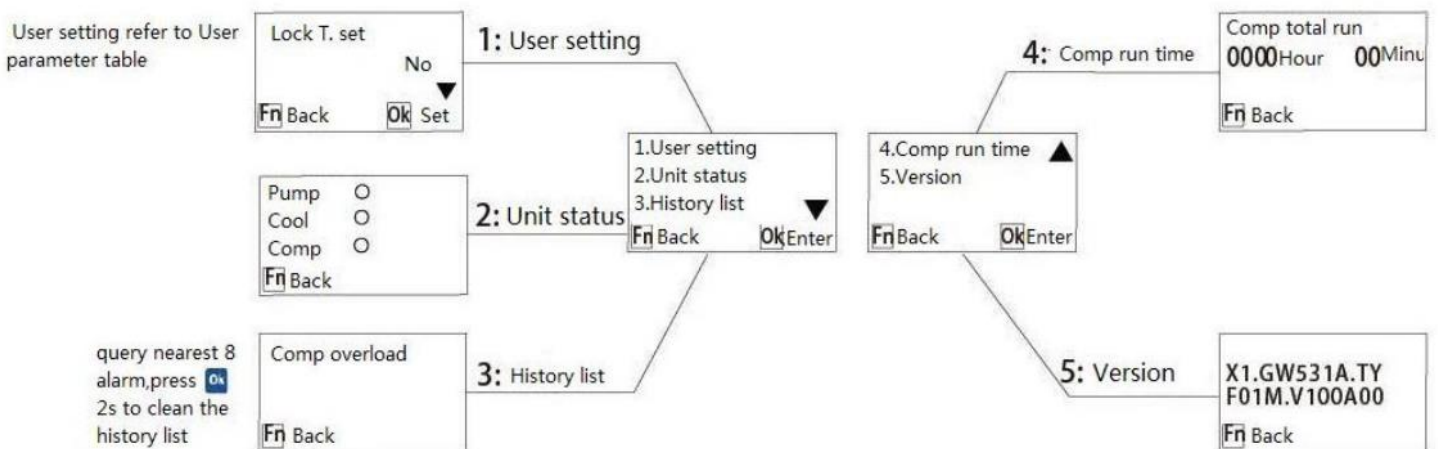

## Parameter Adjustment

To adjust any of the parameters, enter the Function Menu and then enter **1. user setting**. Then select the parameter which is required to be adjusted using the up/down arrows. Press “Ok” to select the parameter. Modify the parameter using the up/down arrows and then save the parameter by pressing “Ok”.

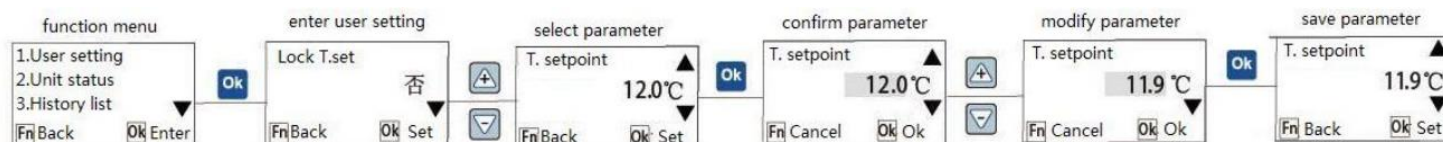

## Parameters

Parameter Name	Default Value	Value Range	Note
Lock T.set	No	Yes/No	Lock Set Temperature
T.setpoint	12.0C	-38.0c – 99.9C	Temperature Limits
Contrast	32	20 - 44	LCD contrast
Run type	Local	Local / Remote	Remote On / Off
Backlight on	0	0 – 255 minutes	Backlight run time (0 = backlight always on)
Language	English	Chinese / English	Select Language



Fault Code Table

Name of failure	Test conditions	Fault handling	The solution
Comp.P high AL	Test when comp running	Stop the compressor,the fan,the pump	If detect input and switch Setting are consistent
Comp.P low AL			
Comp overload			
Temp. low AL	Test when Running	Stop the compressor,the fan,the pump	Raising the temp.
T. high warn		Only report to the police	Cool the Temp.
T. high alarm		Stop the compressor,the fan,the pump	Cool the Temp.
Anti-freeze. AL	Test when power on	Stop the compressor,the fan,the pump	Detect input and switch settings
Probe break			detect the sensor contact
Probe short			
Cool overload	Test after Cooling pump start	Stop the compressor,the fan,the pump	Check cooling overload input and switch settings
Water flow AL	More than set delay time	Stop the compressor,the fan,the pump	Check the water flow and switch settings
Pump overload	Cooling pump start after test	Stop the unit	Check whether frozen overload input and switch settings
A power failure	Test when power on	Stop the unit	check power supply or test switch Setting
Water lv. AL	Test when power on	Stop the compressor,the fan,the pump	
Need maintain	Start testing	Unit can't start once stop, comp. run time is more than setting	

Control Logic

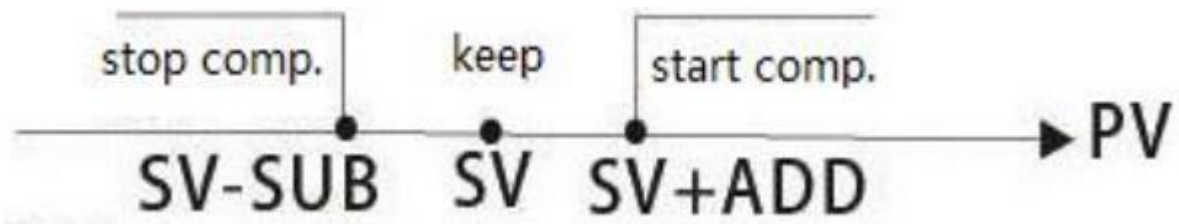

PV = Outlet Temp

SV = Set Temp

Add = Upper range of hysteresis

Sub = Lower range of hysteresis

When temperature rising:  $PV \geq SV + ADD$ , start the compressor

When temp cooling:  $PV \leq SV - ADD$ , stop the compressor.

Electrical Diagram

Electrical wiring diagram

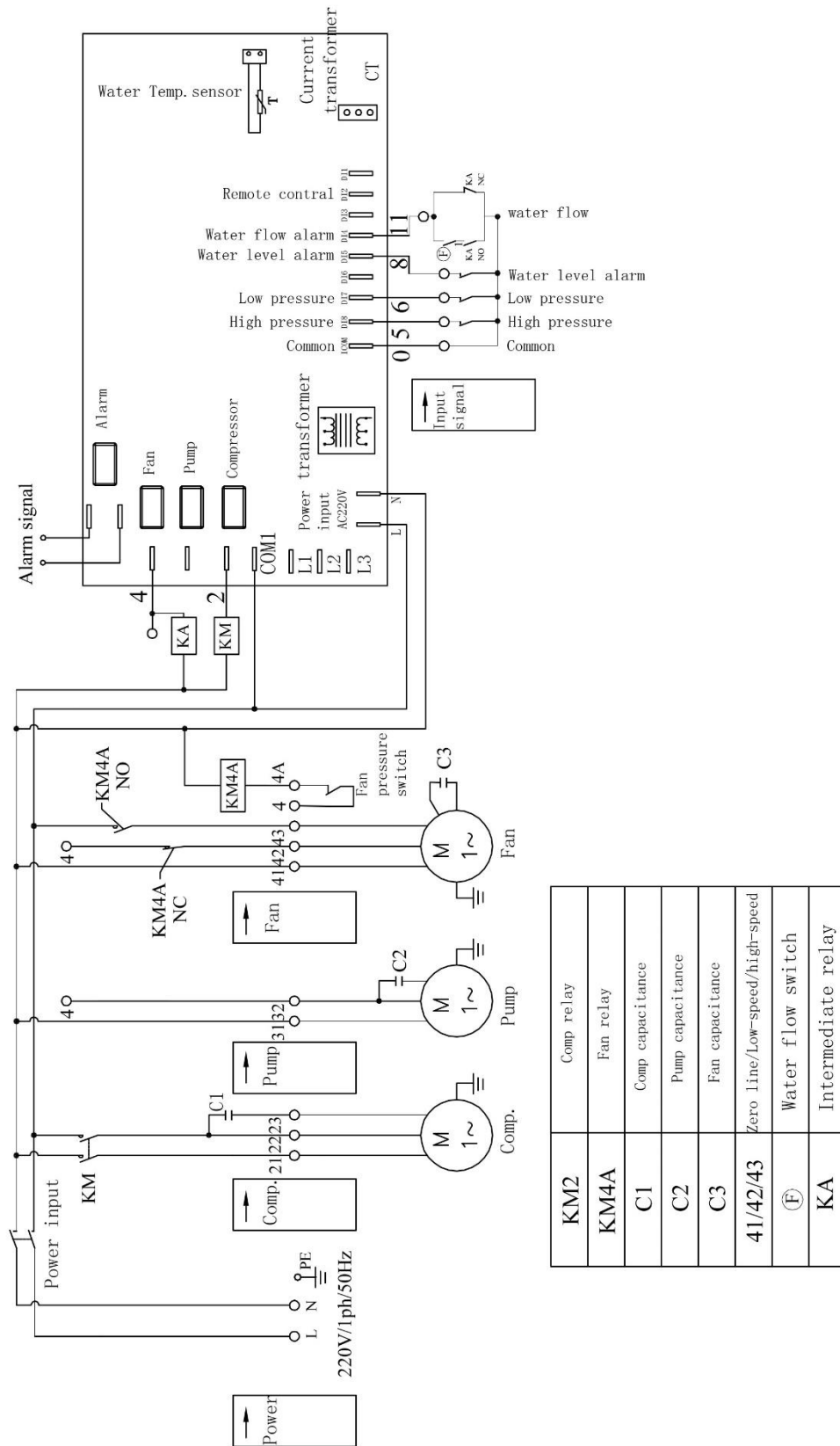



## Troubleshooting

Phenomena	Reasons	Troubleshooting
The suction pressure is too high.	The exhaust pressure is too high.	Refer to “over-high exhaust pressure”.
	The refrigerant is infused excessively.	Discharge excessive refrigerant.
	The thermal insulation of the chilled water pipe is not good.	Check the thermal insulation of pipeline.
	The liquid tube or suction tube is blocked.	Check the refrigerant filter.
	The expansion valve is not well adjusted or of failure.	Adjust the degree of superheat correctly and check whether the temperature response bag is leaked.
	The system refrigerant is short.	Check the leakage of refrigerant.
	Excessive lubricant in the system is in circulation.	Check the volume of lubricant.
	The inlet temperature of chilled water is less than the standard temperature.	Readjust the set value of temperature.
	The chilled water through evaporation is inadequate.	Check the pressure loss of cold water pipe or whether the water pump works normally.
	The exhaust pressure is too low.	Adjust the water pipe valve.
The compressor stops due to high-pressure cut off.	The cooling water is short.	Check the water pipe valve.
	The condenser is blocked and the water enter valve closed.	Check the condenser copper tube and waterway valve.
	The set value of high-pressure protection is not correct.	Check the set value.
	The infused refrigerant is excessive.	Check the refrigerant infusion.
The compressor stops due to overload of motor.	Voltage is too high or low.	Check whether the voltage is consistent with the rated value of the unit. Correct the unbalance of phase if necessary.
	The overload component is of failure.	Check compressor current and compare total current in the data.
	Motor failure or wiring short cut.	Check the impedance between motor wiring seat and earth wire.

## Maintenance

1. To keep the chiller in the best condition, regular maintenance should be conducted on the following items. If necessary, adjust and keep up to date inspection records.

Inspection Time	Items	Methods	Central Control Targets	Aftermath
Daily	Exhaust pressure	Check high-pressure gage	2.2~2.8MPa	MPa
	The exhaust pressure difference among the operating compressors	Check high-pressure gage	<0.1Mpa	MPa
	Suction pressure	Check low-pressure gage	0.02~0.15Mpa	MPa
	The suction pressure difference among the operating compressors	Check low-pressure gage	<0.05Mpa	MPa
	Power supply	Check with voltmeter	Not exceed $\pm 10\%$ of rated voltage	V
	The outlet temperature of chilled water	Check the thermometer.	-5~40°C	°C
	Vibration and noise	Feel and listening	No abnormal vibration and noises	
	Ambient Temperature	Check the thermometer	<42°C	°C

2. The condenser should be cleaned once every three months or in case of abnormally high pressure.
3. If alarm stops operation of the chiller, trained personnel should inspect the unit for any abnormalities
4. After the shutdown of the unit, cut off mains power supply.





## Service and Warranty

1. Maintenance and inspection

After several seasons of use, due to the accumulation of dust on the condenser, the performance of the unit will be reduced. In addition to carrying out daily maintenance and repair yourself, it is recommended that the unit is regularly professionally inspected to keep the chiller in its best condition.

2. Installation and repairs should be conducted by a trained professional. Improper installation or repairs may cause oil leakage, electric shock or fire.

The Crystal8 chillers come with a 12 month Warranty when sold in Australia.

To lodge a warranty claim in Australia please forward as many visual pieces of supporting information and a detailed description of your issue to [beer@kegland.com.au](mailto:beer@kegland.com.au)

If you purchased your unit from an international distributor, you will be required to go through their warranty claims process.

*For a full terms and conditions, please visit our website here -> [Terms & Conditions](#)*