

LLQ Gas Roots Flowmeter



Instruction Manual



HEFEI JINGDA INSTRUMENT CO.,LTD

The enterprise has passed ISO9001 quality management system certification



Catalogue

1. Precautions before use.....	2
2. Usage conditions	2
3. Overview	2
4. Product features	3
5. Structure and working principle.....	3
6. Main technical parameters.....	4
7. Dimensions and Installation of Flow Meter.....	6
8. Instructions for use	8
9. Precautions for use	14
10. Precautions for using explosion-proof products.....	16



Dear customer:

Thank you very much for using our company's Gas Roots Flowmeter! Before use, please read this instruction manual carefully.

1. Precautions before use

1.1 Open box inspection

When users receive this product, they should check the integrity of the external packaging when opening the box, verify the quantity and specifications of the items inside the box according to the packing list, and check the integrity of the instruments and accessories.

Random file:

- a. User manual: one copy
- b. Product Qualification Certificate: One copy

1.2 Handling and Storage

To prevent damage, do not open the packaging of the flowmeter before it is transported to the user's location of use.

- (1) Handle with care during transportation and do not allow rough handling.
- (2) The storage location should meet the following conditions:
 - a. Rainproof and moisture-proof.
 - b. Cannot be subjected to mechanical vibration or impact.
 - c. The ambient temperature range is $-20\text{ }^{\circ}\text{C}\sim+55\text{ }^{\circ}\text{C}$.
 - d. The relative humidity of the environment should not exceed 80%.
 - e. The environment does not contain corrosive gases.

2. Usage conditions

This flowmeter can ensure high accuracy when installed correctly under appropriate flow, pressure, and temperature conditions. Please read this user manual carefully for usage conditions.

3. Overview

The LLQZ intelligent Gas Roots Flowmeter is a volumetric gas flowmeter based on the waist wheel shape with dual rotors and positive displacement. It is combined with built-in temperature and pressure sensors to achieve intelligent integrated flowmeter with temperature and pressure compensation correction.

Suitable for non corrosive gases such as natural gas, city gas, propane, butane, air, nitrogen, and industrial inert gases.

It is mainly used for gas commercial settlement in industries such as catering and hotels, gas



metering in transmission and distribution pipelines, gas pressure regulating stations, industrial and civilian boilers, and can also be used as a standard flow meter.

This product complies with JB/T7385-2015<Gas Roots Flowmeter>and JJG633-2005<Gas volumetric flowmeter calibration regulations>.

4. Product features

1. Reliable operation and long lifespan. The high-precision machining and balanced waist wheel rotor, surface high hardness treatment, non-contact and well worn lubrication environment ensure the long-term reliable operation of the flowmeter.

2. Wide flow range and low initial flow. Suitable for measuring gas flow with large load changes, the accuracy of flow measurement is not affected by pressure and flow changes, the performance is stable, and the service life is long.

3. High accuracy, reliable measurement performance, no need to adjust accuracy, and not affected by changes in the measurement medium conditions.

4. Adopting low-power high-tech, internal and external power supply for operation, the whole machine has low power consumption

5. Dual power supply function, which can achieve low power consumption by using built-in lithium batteries for power supply, as well as bidirectional two-wire power supply and output signal mode, and also has RS485 communication function.

6. Built in temperature and pressure compensation can directly compensate for real-time density and calculate the standard volumetric flow rate of the medium.

7. The integrated intelligent processing inside the integrator ensures stable and reliable measurements under external interference, with optimal process reliability.

8. It has floating-point operations and automatic correction of multi terminal instrument coefficients, as well as fault self diagnosis and alarm functions.

9. The large screen LCD displays various parameters such as total volume, flow rate, temperature, pressure, density, and battery capacity, and has a display function for fault alarms, as well as multiple signal outputs.

10. It has real-time data storage function, which can prevent data loss caused by battery replacement or sudden power failure; In the event of a power outage, internal data can be permanently saved or a large amount of historical data during operation can be queried.

5. Structure and working principle

5.1 Flowmeter structure

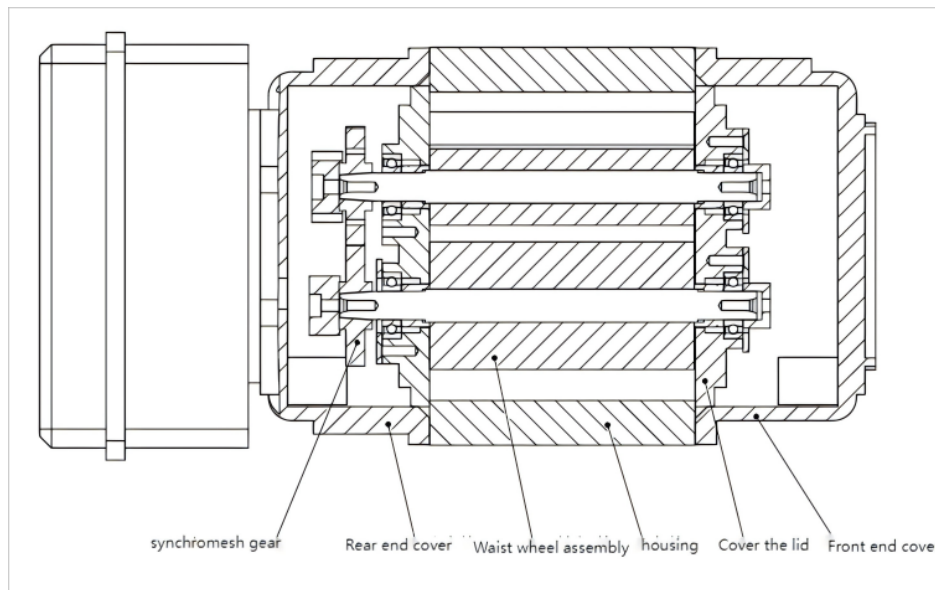

5.2 Working principle

This flowmeter is a positive displacement flowmeter, and the measuring chamber consists of two rotors with a waist wheel shape in cross-section that mesh and rotate. As gas flows through the measuring chamber, the pressure difference force generated between the inlet and outlet of the measuring chamber drives the two waist wheel rotors connected to a pair of high-precision synchronous gears to rotate, completing the rotation process from A-B-C-D. The gas in the measuring chamber formed by the enclosed space between the inner wall and cover plate of the measuring chamber and the pair of waist wheel rotors periodically enters and exits the chamber; The rotational speed of the waist wheel rotor is proportional to the flow rate of the measured gas passing through the flowmeter. The rotational speed value is transmitted through a dedicated sensor to the integrator for shaping and filtering, and then converted into a standard voltage pulse signal output. The frequency of the pulse signal is proportional to the common volume flow rate of the fluid inside the pipeline.

The built-in high-precision pressure and temperature sensors simultaneously measure the temperature and pressure of the fluid and transmit signals into an integrated intelligent integrator. The integrator converts the signals of flow rate, temperature, and pressure and accurately calculates and integrates them to accurately measure the standard volume flow rate and mass flow rate of the gas.

6. Main technical parameters

6.1 Flow meter specifications, basic parameters, and performance indicators (see Table 1)



Table 1

Specification and model	Nominal diameter (mm)	Flow range m ³ /h	Start flow rate m ³ /h	Pressure loss at Q _{max}	Accuracy %	Nominal pressure MPa
LLQZ-25	25	1-25	0.05	0.08	1.0 1.5	1.6
LLQZ-40	40	1-40	0.07	0.08		1.6
LLQZ-50A	50	2-65	0.1	0.1		1.6
LLQZ-50B	50	2-100	0.1	0.15		1.6
LLQZ-80A	80	3-160	0.12	0.15		1.6
LLQZ-80B	80	3-250	0.15	0.18		1.6
LLQZ-100A	100	4-300	0.11	0.35		1.6
LLQZ-100B	100	4-500	0.1	0.46		1.6
LLQZ-150A	150	8-650	0.65	0.47		1.6
LLQZ-150B	150	15-1000	0.76	0.49		1.6

6.2 Measurement medium

Various gases such as natural gas, city gas, alkanes, and industrial inert gases.

6.3 Electrical performance indicators:

a. Working power supply:

Internal power supply: One 3.6V lithium battery with real-time display of battery capacity on the screen. The battery can work normally when the voltage is within 3.0~3.6V. When the voltage is below 3.0V, there is no battery capacity grid display and the battery needs to be replaced.

External power supply: +24VDC \pm 15%, ripple \leq 50mV. When connected to the external power supply, the internal power supply automatically disconnects and the entire machine is powered by the external power supply.

b. Output mode (requires external power supply +24V):

Output of working condition pulse signal (three wire system): directly amplify and output the working condition pulse signal detected by the flow sensor, with an amplitude of 20-24V and a transmission distance of \leq 300m.

4mA~20mA standard analog signal output: The 4mA~20mA standard analog signal linearly corresponds to (0~Q_{max}) m³/h (standard instantaneous flow), with a flow range set by the instrument, a transmission distance of \leq 1500m, and a power supply of +24VDC external power supply.

RS-485 interface signal output: directly connected to the upper computer, it can remotely transmit the temperature, pressure, instantaneous flow rate, standard volume flow rate, and



instrument related parameters of the measured medium.

6.4 Whole machine power consumption:

- a. Internal power supply: The average power consumption is 3mw, and one lithium battery (15Ah) can be used for at least two and a half years.
- b. External power supply: The overall power consumption of the machine is $\leq 1W$.

6.5 Real time data storage function:

In order to meet the needs of data management, real-time data storage functions have been added, including:

- a. Monthly net traffic for the past 12 months.
- b. Net daily traffic for the past 360 days.

The above stored data can be read using a laptop or desktop computer through the RS-485 interface, and data reports and curve graphs can be generated for analysis according to user needs.

7. Dimensions and Installation of Flow Meter

7.1. As shown in the external drawing of the flowmeter, the dimensions of the flowmeter are labeled in Table 2,

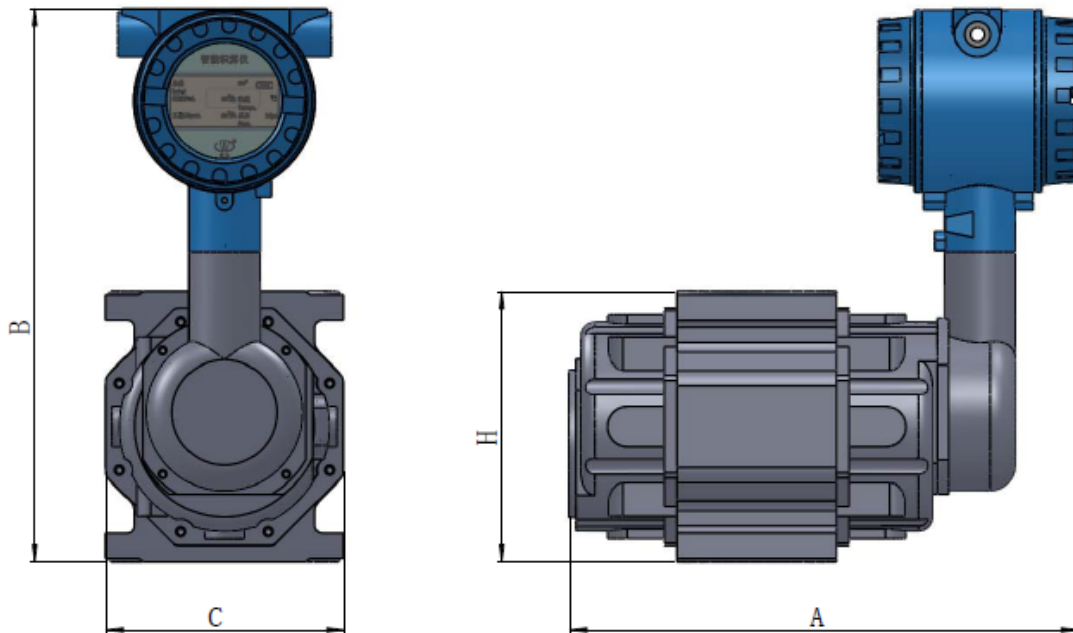

Table 2

Model	DN	A	B	C	H	1.6MPa	Remarks
-------	----	---	---	---	---	--------	---------



						D	K	n-d	
LLQZ-25	25e	230	290	200	128	115	85	4-Ø14	Flange standard HG/T20592
LLQZ-40	40	280	290	200	128	150	110	4-Ø18	
LLQZ-50A	50	370	350	200	192	165	125	4-Ø18	
LLQZ-50B	50	410	350	200	192	200	160	4-Ø18	
LLQZ-80A	80	450	350	200	192	200	160	8-Ø18	
LLQZ-80B	80	340	400	230	245	220	180	8-Ø18	
LLQZ-100A	100	540	400	230	245	220	180	8-Ø18	
LLQZ-100B	100	630	400	230	245	220	180	8-Ø18	
LLQZ-150A	150	670	490	450	460	285	240	8-Ø22	
LLQZ-150B	150	880	490	450	460	285	240	8-Ø22	

7.2 Installation of Flowmeter

Based on the characteristics of the Roots flowmeter, it is recommended to use a vertical flowmeter with a gas flow direction of inlet and outlet. In special circumstances, left in and right out can be adopted.

The installation of flow meters should be equipped with front and rear valves and bypass pipelines to ensure that there is no need to stop the gas during maintenance.

Strainer Front valve



Medium flow direction

Flowmeter

Bypass-valve

Back valve

Vertical installation diagram

Front valve Strainer Flowmeter Steel expander Back valve

Medium flow direction

Horizontal installation diagram

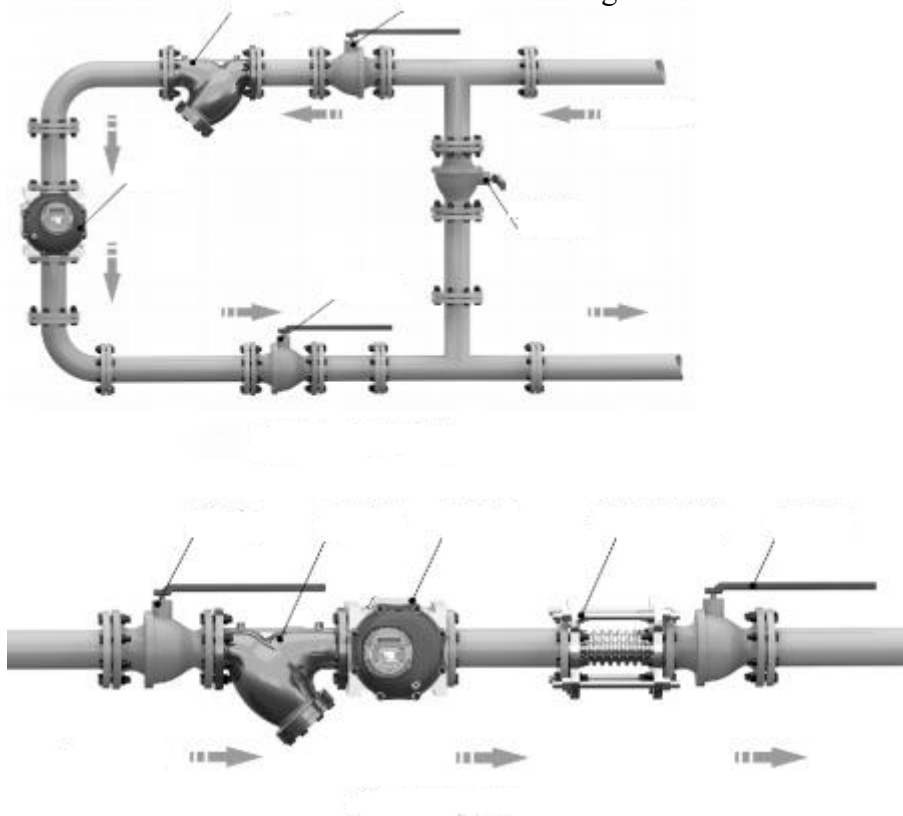

8. Instructions for use

8.1 Display content in working state

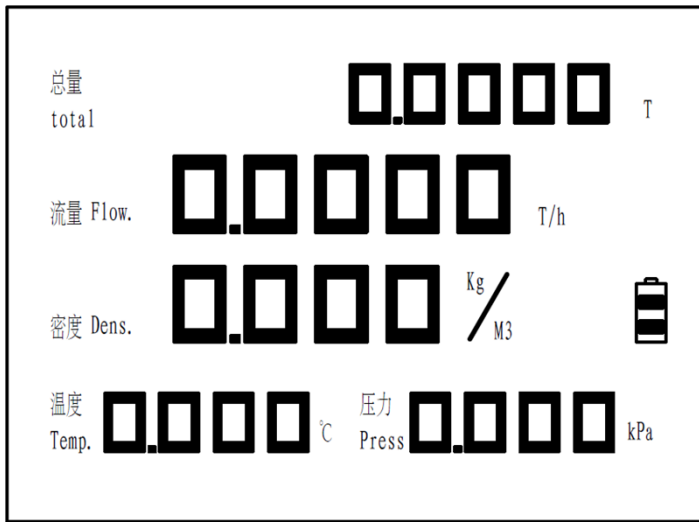

Measurement of steam medium

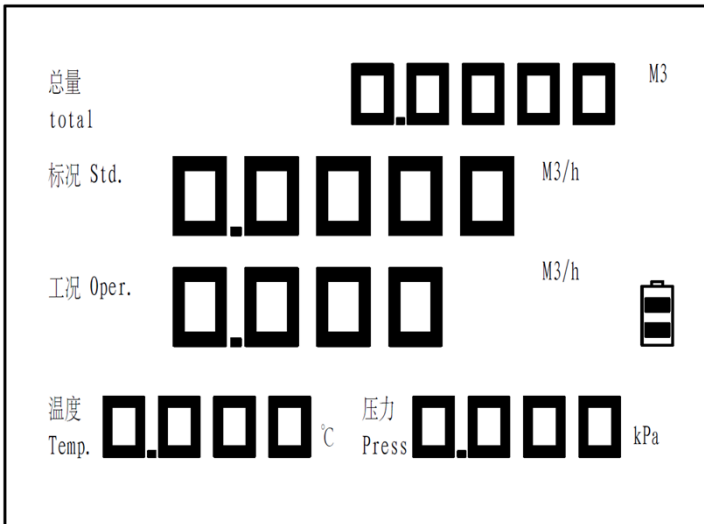

Measurement of ordinary gas medium

Total Quantity: Quality/Standard Volume Total Quantity, with ten digits and one automatic decimal point, can display up to four decimal places. Units:m³, L, T, Kg.

Standard condition: instantaneous flow rate of standard volume, six digits, one automatic decimal point, up to four decimal places can be displayed, units: m³/h, L/h, T/h, Kg/h.

Working condition: instantaneous flow rate of working condition volume, five digits, one automatic decimal point, up to three decimal places can be displayed, units: m³/h, L/h, T/h, Kg/h.

Flow rate: When measuring steam, display instantaneous flow rate with six digits, one automatic decimal point, up to four decimal places, in units of T/h and Kg/h.

Density: Real time density of steam displayed during steam measurement, in Kg/m³.

Temperature: The displayed value is - XXX X °C to XXXX °C, one symbol, four digits, one automatic decimal point, unit: °C.

Pressure: Four digits, one decimal point, minimum display value can retain one decimal place, maximum value is 9999KPa, flashing when exceeded, unit: KPa.



Battery level indicator, half grid display when battery level is low, user needs to replace battery. (No battery level indicator box when connected to an external power source)

8.2 Parameter Setting of Flowmeter

Open the back cover of the monitor, the instrument panel has four buttons: increase (K1), shift (K2), confirm (K3), and return (K4), as shown in the following figure

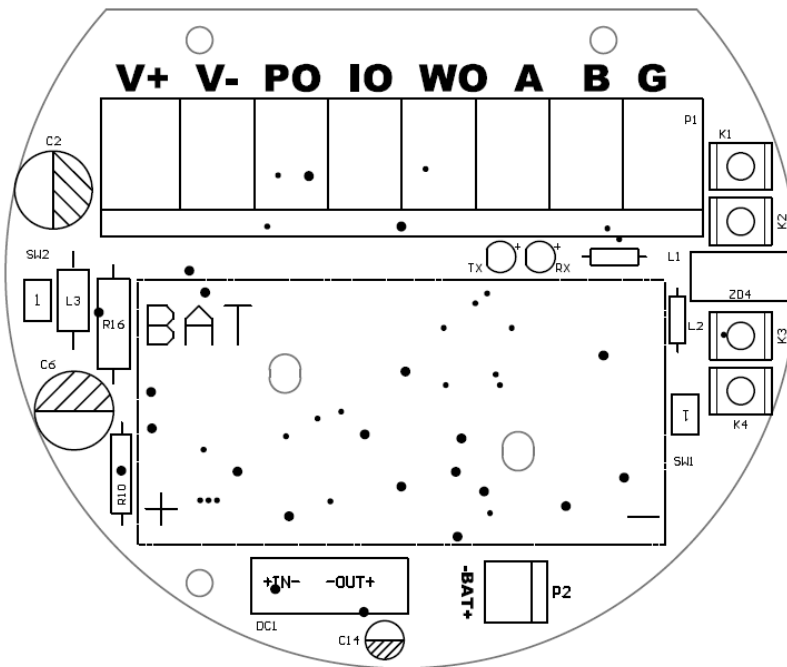

K1: Increase
K2: Shift

K3: Confirm
K4: Return

Add key (K1): The flashing digit increases.

Shift key (K2): The flashing position shifts to the left.

Confirm key (K3): Enter the password input interface, confirm and modify parameters.

Return key (K4): Exit the modification interface and finally store the parameters.

8.3 Flowmeter interface settings

The code, definition, and operation of each parameter of the flowmeter are shown in the table below, and users are not allowed to change them arbitrarily.

Menu	Show contents	Function definition	Remarks
Password input interface	Pad-XXXX	Password input	The correct password allows for parameter modification Otherwise, only various parameters can be browsed The initial password is 1 You can change this password in the following



			menu
	F XXXX	Real time frequency	Read only
	DXX	Alarm sign	Read only
F01	XX XX XX XX XX	Beijing time	Year Month Day Hour The setting range for the year is from 00 to 99 Modifiable
	Nyc XX	Software compensation mode 0~07	00: No compensation, no correction 01: C compensation, Z not corrected (take 1); 02: C compensation, Z correction takes a constant, operated by keyboard; 03: C compensation, Z correction, automatic calculation of Z parameters 04: C compensation, saturated steam pressure compensation mode only measures pressure 05: C compensation, saturated steam temperature compensation mode only measures temperature 06: C compensation, automatic steam state judgment mode 07: C compensation, steam density setting mode, density needs to be set
	P xx		
	T xx		
F02	C-X.XXXX	Z coefficient setting Z coefficient refers to the compression factor of natural gas	Default is 1 Adjustable range 0.5~1.9999
	DM XX	Damping coefficient	1~64S, current output is affected
	PE XX	Temperature and pressure collection cycle	Unit: s Default value 05 s Set range 2-20s
	Un X	Flow unit setting	1 L 2 M3 3 kg 4 T
F03	D-XXXXXX_X	Gas density setting	Unit: kg/M3 Valid when the unit is set to KG/T Steam metering is used as a backup density Used for medium density in other measurements, carefully set _Representing the decimal point _The X at the end represents the number of decimal places
	FL XXX	Frequency cutoff setting	Remove small frequencies
	CL n	Total accumulated amount reset to zero	0 reset>0 unclear
	JZ X	AD acquisition calibration	0 calibration>0 non calibration The temperature sensor needs to be disconnected during calibration, otherwise it may cause



			acquisition errors
F04	Pv xxxx. x	Maximum output mv value of pressure sensor	This value is the output voltage value of the pressure sensor under 4ma excitation current. If the parameter table shows 1ma, please multiply the parameter by 4 before inputting
	HXX. XX	Upper limit pressure alarm value	Unit Mpa
	LXX. XX	Lower limit pressure alarm value	Unit Mpa
	PU X	Pressure display unit	Reserved function
F05	Pk x.xxxx		
	Pxxx.xx	Local atmospheric pressure value	Set the range of 86~110kpa, and call the default 101.32 for the gauge pressure sensor
	Pm xx. x	Maximum measuring range of pressure sensor	Unit Mpa
	Pdx	Type of pressure sensor	1 Absolute pressure sensor 2 gauge pressure sensors
F06	Tk x.xxxx		
	HT XXX	Upper limit temperature alarm value	Unit °C Maximum 405 °C
	LT XXX	Lower limit temperature alarm value	Unit °C
	Td x	Temperature sensor type	Reserved function
F07	L_P Xx.xx	Calibration output pulse equivalent	0.01~99.99m3 (or T) default 1.00
	Opd x	Pulse output mode	Pulse output under working condition 1, with a high-level pulse width of less than 0.5ms 2 Modulation pulse output 1 Output pulses according to the set pulse coefficient Pulse high-level width less than 0.5ms 3 calibration pulses output 400us
	Cn XXX	postal address	Set up to 1-256, default is 01
	RTDX	485 output mode	0 RS485 communication output off RS485 communication protocol Ver2.0 RS485 communication protocol Ver1.0 (MODBUS_STU) - Default
F08	2na XXXXX_X	20ma corresponds to flow rate	The unit is the same as the set unit
	XXXXX	4ma calibration	At this point, the displayed value is the actual AD value, with a maximum setting of 60000
	XXXXX	20ma calibration	Same as above, the maximum setting is 90000
	Ma X	20ma corresponds to the setting of total quantity properties	0 standard flow rate 1. Operating condition flow rate
F19	Pad XXXX	Password 20	Enter 20 to enter the instrument coefficient modification interface If the password is entered correctly, the menu



			will cycle between F20 and F29 Press the exit button on the display (non modification interface) to return to the normal modification interface
F20	A-XXXXXX_X	Average instrument coefficient	When OPD-2, output pulses according to this instrument coefficient
F21	XXXXXX_X	The first instrument coefficient	
	XXXX	Segmented frequency	Below this frequency, use this instrument coefficient for this range
F22	XXXXXX_X	Second section instrument coefficient	
	XXXX	Segmented frequency	
F23	XXXXXX_X	Third section instrument coefficient	
	XXXX	Segmented frequency	
F24	XXXXXX_X	The fourth section instrument coefficient	
	XXXX	Segmented frequency	
F25	XXXXXX_X	Fifth section instrument coefficient	
	XXXX	Segmented frequency	
F26	XXXXXX_X	The sixth section instrument coefficient	
	XXXX	Segmented frequency	
F50	Pad XXXX	New password	
	NO/YES	Determine whether to modify	
F51	Ftr x	Factory settings	2. Restore factory settings (password correct)
	NO/YES	Determine if	

***Fault display instructions**

Fault location	Reason for malfunction	Fault code (displayed)
----------------	------------------------	------------------------



D0	Pressure exceeds the maximum range of the sensor	D0
D1	Pressure exceeds the maximum alarm pressure set by the user	D1
D2	The pressure is less than the minimum alarm pressure set by the user	D2
D3	The temperature exceeds the maximum alarm temperature set by the user	D3
D4	The temperature exceeds the maximum allowable temperature ZQT-MAX	D4
D5	Low battery	D5

8.4 Internal wiring method of flow integrator

Before wiring operation, the 24V external power supply should be disconnected first, and live operation is never allowed. Connect the wires according to the following diagram.

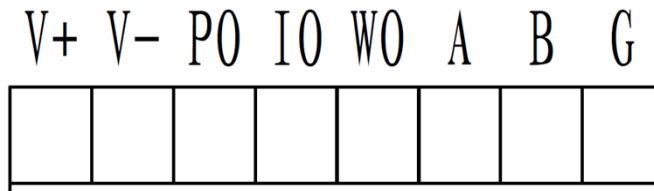

The functions of each lead marking are as follows:

V+- Positive pole of pulse/analog output power supply;

V - Pulse output external power supply negative pole;

PO - Pulse output;

Io-4mA~20mA output;

A. B-RS485 communication line;

G - Communication shielded wire

8.5 System Wiring Diagram

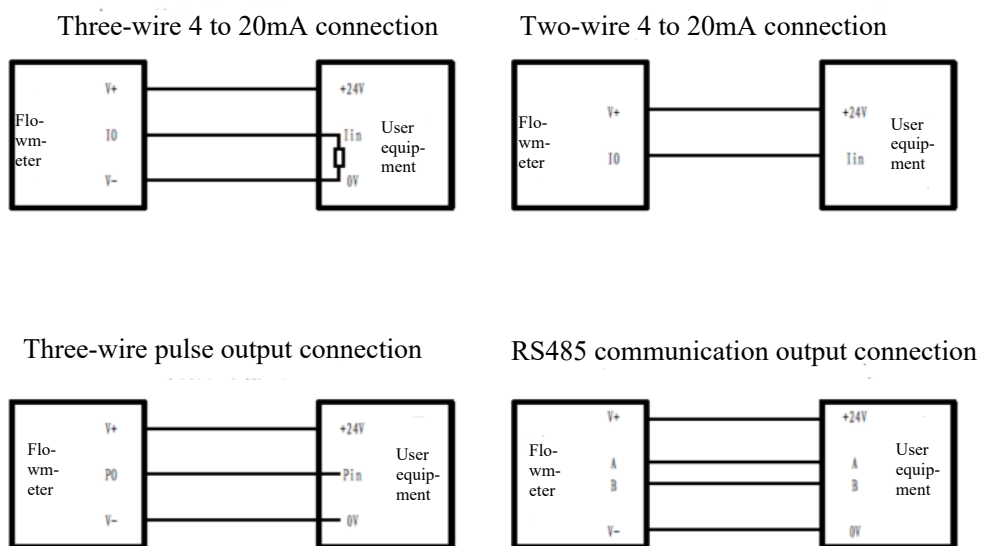

8.6 4~20mA current output section instructions

The maximum resistance of the two-wire 4mA~20mA current output loop is 50 ~ 500Ω

The maximum resistance of the three-wire 4mA~20mA current output loop is 50 ~ 800Ω



8.7 Use of power supply

3.6V lithium batteries can generally be used for 30 months. The battery level indicator shows that there is no power when the voltage is below 3.0V, and the user needs to replace the battery. When replacing, open the lead seal and unscrew the back cover to remove the old battery and insert a new one (pay attention to the battery polarity!), then cover the back cover.

8.8 Fluid conditions

a. The measured fluid should be a gas without vortices (including air), and free of impurities such as large particles and fibers (cannot measure gas-liquid mixed flow);

b. The flow rate and pressure range of the measured fluid should be within the range specified by the flowmeter;

9. Precautions for use

Before installation and use, users should read this instruction in detail to ensure the correct installation and reasonable use of the flowmeter, so as not to affect the positive regular operation and measurement accuracy.

Before installation, the pipeline must be blown clean; A gas filter needs to be installed before the flowmeter; Do not use straight pipe sections; Flowmeters should be protected against to stop the violent impact of the fluid, when using a flowmeter, first open the front valve of the flowmeter, then slowly open the valve at the back of the flowmeter. When turned on, the boost speed should be $\leq 100\text{mbar/s}$.

1. Before installing the flowmeter, the inlet and outlet packaging should be removed to prevent particulate impurities from falling into the measuring chamber. If the surface of the measuring chamber is coated with rust proof oil, it can be washed clean with gasoline or kerosene, and impurities in the pipeline should be strictly removed. Filters and screens should be installed on the flowmeter to prevent rust, welding slag, and other impurities from entering the measuring chamber.

2. When installing the flowmeter, regardless of whether the inlet and outlet are in a vertical or horizontal position, the rotor axis should be kept as horizontal as possible.

3. When the gas pressure fluctuation range is large, a pressure regulator should be installed upstream of the flowmeter to ensure measurement accuracy.

4. To prevent rust, welding slag, and other impurities from entering the flowmeter in the newly installed pipeline, users should first install the transition pipe at the installation position of the flowmeter, ventilate for a period of time to ensure that there are no large particle impurities, and then replace the flowmeter. If the pipeline is welded, a transition pipe should be used instead of directly welding with the flowmeter.



5. There are two forms of installation for flow meters: vertical installation at the inlet and outlet and horizontal installation at the inlet and outlet. It is strongly recommended to install the flowmeter vertically, where the gas flow direction is upward and downward. This installation allows the rotor to have self-cleaning ability against impurities in the pipeline (also known as left in and right out). When installing the flowmeter, front and rear valves and bypass pipelines should be set up to ensure that the gas does not have to be stopped during maintenance.

6. The dimensions of the piping and fittings in each part of the flowmeter installation pipeline must be appropriate. When installing a flowmeter, it should be ensured that the center of the flowmeter is aligned with the center of the pipeline, without any misalignment, and that the flowmeter body is subjected to abnormal external forces (including axial and radial forces).

7. After installation, unscrew the screw plug on the back cover and use an Allen wrench to turn the rotor to check if it rotates freely. If there is a blockage in the rotation of the rotor, the instrument should be removed, the dirt should be cleared, and then reinstalled. After the rotor rotates freely, tighten the screw plug.

8. After the flowmeter is installed correctly, inject special lubricating oil from the oil injection button to the centerline of the oil window (note not to add too much). During use, check regularly or irregularly to ensure the adequacy and cleanliness of the lubricating oil. If the lubricating oil turns black or the oil level is higher than the centerline of the oil window during use, it indicates that the lubricating oil has deteriorated or has impurities. At this time, new lubricating oil should be replaced. If the oil level is lower than the centerline of the oil window, it indicates that the lubricating oil is lost and needs to be replenished to the centerline of the oil window. When adding lubricating oil, the front and rear valves of the flowmeter must be closed, and the gas inside the flowmeter must be emptied before adding lubricating oil.

9. When the flowmeter is put into operation, first open the bypass valve and the outlet valve of the flowmeter, slowly open the inlet valve, and let the flowmeter run at a low flow rate for a few minutes, listening for any abnormal sounds. After the flowmeter starts normally, gradually close the bypass valve and adjust the outlet valve to a certain opening to ensure that the flowmeter runs normally at a certain flow rate. Be sure to open and close the valve slowly to prevent strong impact of airflow from damaging the flowmeter.

10. After the flowmeter is put into operation for a period of time, if the pressure drop of the filter increases, the filter should be cleaned or the filter medium should be replaced; If the pressure drop of the flowmeter increases and the starting flow rate rises, clean gasoline or kerosene can be used to flush the measuring chamber.



10. Precautions for using explosion-proof products

This product is an explosion-proof product, and the following precautions should be taken when using it:

1. The product casing is equipped with a grounding terminal, and users should ensure reliable grounding when using the product.
2. On site installation and maintenance must comply with the warning message 'Open the cover after disconnecting the power supply'.
3. There should be no harmful gases present at the installation site that can corrode aluminum alloys.
4. The maximum allowable temperature of the tested medium is +80 °C.
5. Repairs and battery replacements must be carried out in a safe place, and repairs can only be carried out when the installation site confirms the absence of flammable gases.
6. When installing, using, and maintaining products, users must comply with the relevant provisions of GB50058-92 "Design Code for Electric Power Installations in Explosive and Fire Hazardous Environments" and "Electrical Safety Regulations for Explosive Hazardous Areas of the People's Republic of China".

When using an external power source or external signal, the outer diameter of the rubber cable should be $\phi 7 \sim \phi 8$; If external power supply and external signal are not used, the cable outlet hole must be sealed tightly with a blind plate.

When the product is used outdoors, a waterproof cover must be added.

JINGDA service concept

- Ensure that customers rest assured to choose fine large products.
- The convenience of customers is the trust of enterprises.
- Every day a company loses a customer is another day it loses a market.
- Service first find their own problems, giving priority to the interests of customers.
- Customers will not use JINGDA products, it is not the customer's fault, but our service work is not done.

JINGDA service principle

- Process first, analyze later.
- Act first, talk later.
- Get it right the first time.



Add: No.75 Science Avenue, High-tech Industrial
Development Zone, Hefei City, Anhui Province, China.

Postcode: 230088

Marketing Department : +86 0551-65312888

+86 13955159439

Free Phone: +86 4008872309

Website : <http://www.jdkjhf.com>

E-mail: jd88@sina.cn