

## CONTACT US

JNTech Renewable Energy

📍 28 Taiyuan Road Hefei, Anhui, China 230051

☎ +86-551-62930323

📠 +86-551-65393686

✉ sales@jnnewenergy.com

🌐 www.jntechenergy.com



**jntech**  
make the world greener

# Microgrid Application System Solution

Efficient

Green

Energy-saving



# CONTENTS



## ONE

---

About JNTech	01
--------------	----

## TWO

---

Global Sales Network	03
----------------------	----

## THREE

---

Production Base	05
-----------------	----

## FOUR

---

Core Products	07
---------------	----

## Five

---

Business Areas and Their Introduction	09
---------------------------------------	----

## Six

---

Case demonstration	35
--------------------	----



# ABOUT JNTECH

JNTECH is a global leader in advanced micro-grid solutions, committed to providing reliable and sustainable energy systems that address the unique challenges of diverse regions worldwide. Since our founding in 2006, we have focused on providing stable, affordable, and sustainable power through green energy for more people. To achieve this, we have developed a diverse portfolio of solutions that can adapt to different markets and needs. Currently, our products are sold in over 100 countries and regions.

As a leading manufacturer and provider of solar and new energy products, JNTECH specializes in innovative technologies to meet a wide range of energy requirements. Our solutions include home energy storage systems, solar water pumping systems, solar oil extraction systems, solar mining systems, solar irrigation systems, electric vehicle charging systems, and other micro-grid solutions. These solutions incorporate both our proprietary products and those from other providers, ensuring comprehensive support for agriculture, remote power, and carbon footprint reduction.

With extensive experience and technical expertise in photovoltaic micro-grid projects, JNTECH has established strong partnerships with organizations such as the World Bank, United Nations, IBRD, FAO, and various NGOs. These collaborations underscore our commitment to advancing sustainable energy solutions on a global scale. We believe that the widespread adoption of clean energy will enhance convenience and development opportunities for communities worldwide.

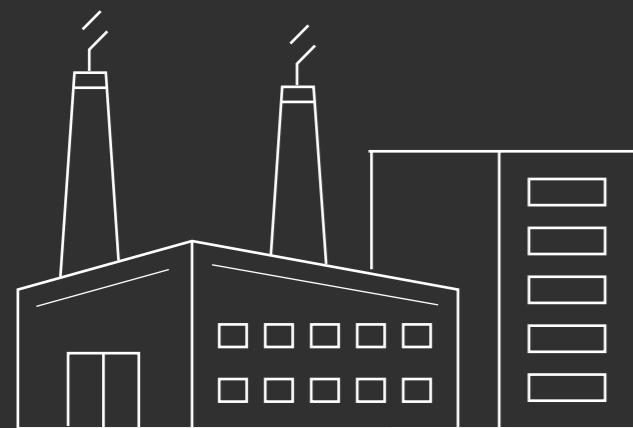

## Qualifications and Honors

- ▶ National Standard Drafter
- ▶ United Nation Global Marketplace Supplier
- ▶ Specialized and New Enterprise
- ▶ National High-Tech Enterprise
- ▶ National Innovative SME
- ▶ Anhui Province Specialized in Special New Enterprises
- ▶ CE, TUV, ISO9001, ISO14001, and OHSAS18001 Certifications

## Service

### Pre-sales

- ▶ Investment Consultation
- ▶ Site Selection Assistance
- ▶ Customized Design Solutions
- ▶ Site Construction Support
- ▶ Operations and Maintenance Planning

### After-sales

- ▶ Standardization of Workflow, Operations, and Policies
- ▶ Technical Services, Marketing Support, and Training Programs
- ▶ Collaborative Platform for Technical Exchanges
- ▶ Creating Value through Win-Win Cooperation
- ▶ 24/7 Online Support and Service

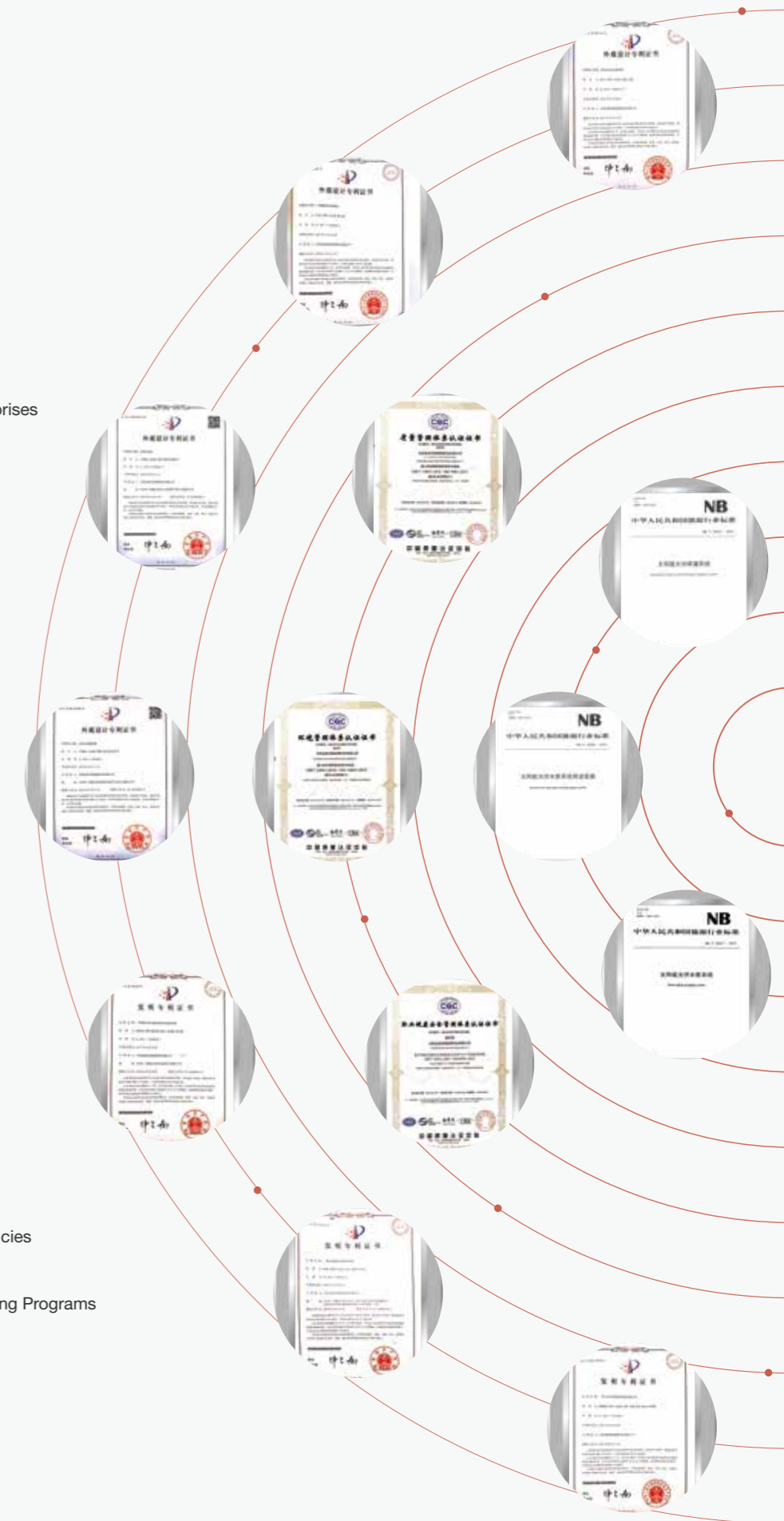

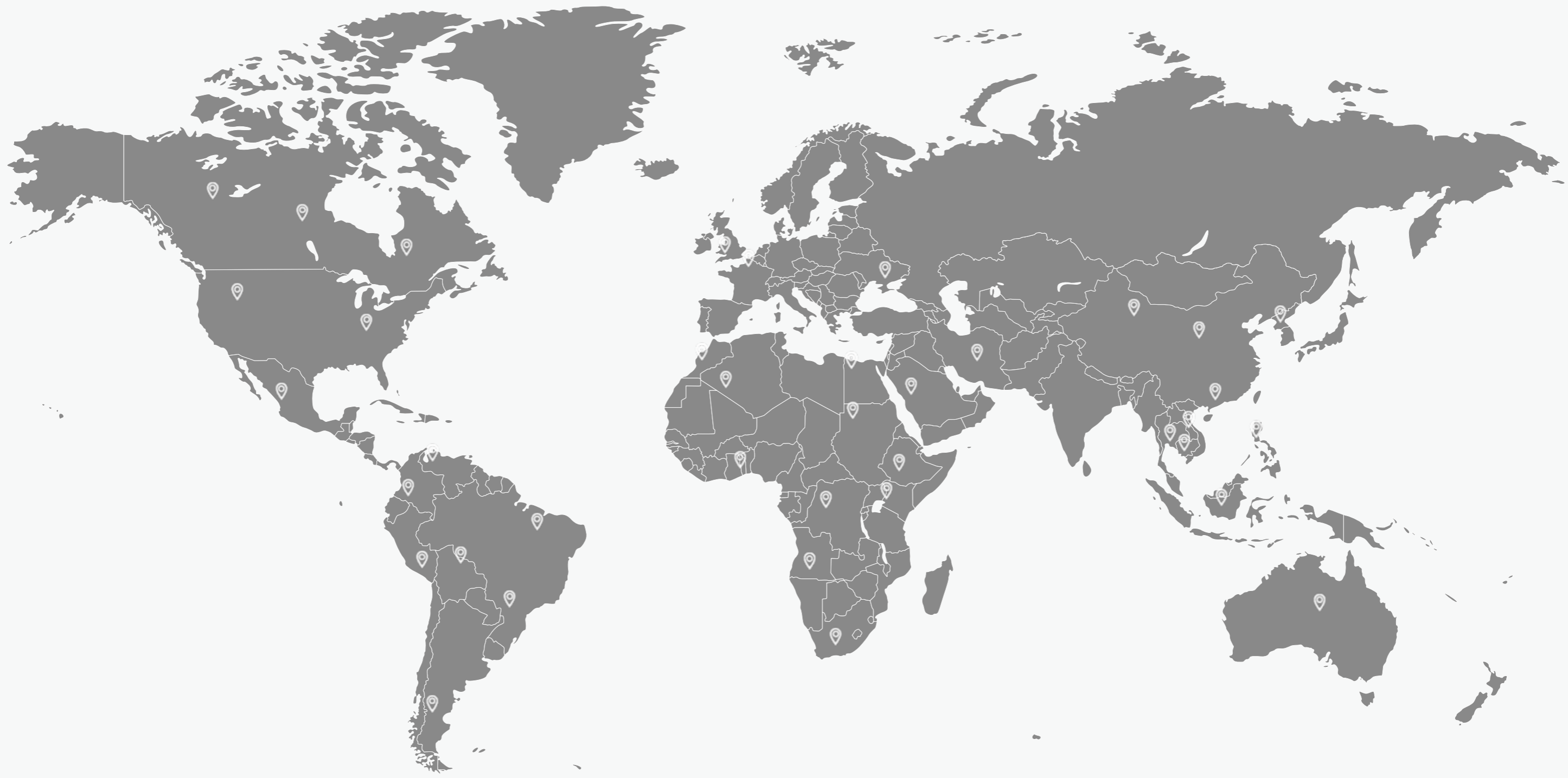

---

**GLOBAL SALES NETWORK**

**15+**

Years of Experience in Solar Industry

**40%+**

R&D Employees

**100+**

Countries and Regions

**10,000+**

Global Clients

**1,000,000+**

Products Sold



# PRODUCTION BASE

Three major production bases in Hefei, Xuancheng and Chuzhou



R&D and Manufacturing Integrated  
Intelligent Production Line

- Technical advantages
- Manufacturing advantages
- Experience advantages



## CORE PRODUCTS



### Industrial and Commercial Energy Storage Cabinet

30kW/30kWh – 100kW/  
200kWh

#### Features:

- Integrate the phosphate iron lithium battery system, AC/DC bidirectional inverter system, temperature control system and fire protection system
- Intelligent, modular design, simple structure and easy maintenance
- Integrate EMS and be easy to set peak and off-peak periods
- Redundant Design of AC/DC Dual Auxiliary Power Supply
- It has a small footprint, is cabinet-style designed, and the equipment can be installed and used immediately upon arrival



### Energy Management System EMS

Power input: DC24V(18V~32VDC)(≤3A)

#### Features:

- Can be applied to a variety of energy storage systems, fast response speed
- Real-time monitoring and remote control can dispatch and balance power resources
- With a high-performance processor, 4 cores, 4 threads
- Modular design for easy installation and maintenance
- With input anti-reverse, anti-surge protection
- A backup battery is integrated to ensure data backup and maintain normal operation for a short period of time when the system is powered off



### Liquid Cooled Energy Storage Cabinet

215kWh

#### Features:

- High safety: Complete certification, multiple protections, one cluster one management, no circulation, and segmented direct current short-circuit current
- Long lifespan: The battery can be cycled up to a maximum of 12,000 times. There is still a 70% energy retention rate after 10 years (two charging and two discharging). The liquid cooling mode has a longer lifespan. The designed service life under standard conditions is 15 years
- Easy configuration: Communication and integration of machines, with the ability to add parallel machines at any time, and flexible site layout
- Parallel and off-grid: Can achieve off-grid operation and anti-backflow function



### High-voltage Photovoltaic Charging Module

3kW-50kW

#### Features:

- Advanced MPPT tracking algorithm, tracking efficiency is greater than 99%
- Using IGBT as electronic switch and multi-phase synchronous rectification technology, the stability of the equipment is improved
- Ultra-wide input voltage range, saving busbar wire and construction costs
- With voltage loop and current loop double loop control
- Charge and discharge of controller CAN be controlled by RS485 and CAN
- Standard Modbus communication protocol based on RS-485 communication bus



### Energy Storage Battery Cabinet

30kWh – 1000kWh

#### Features:

- Complete electrical protection function, fault alarm, fault protection, safety protection and other functions
- The emergency braking function, the emergency stop function and the function that can disconnect the system step by step during maintenance
- High altitude design, special DC switches are considered high altitude on the switch cut-off and voltage
- Long service life, service life > 10 years, cycles > 6000 times
- Low voltage design, safe and reliable, rack design, meet the requirements of industrial and commercial use environment



### Energy Storage Converter PCS Module

50kW - 125kW

#### Features:

- Three-phase four-wire output, compatible with single-three-phase load
- Battery configuration is diverse, lead acid or lithium batteries can be freely matched
- Perfect protection mechanism, high reliability, good security
- Supports RS485 and CAN communication
- Support master-slave multi-machine parallel function (later upgrade)



### Container Energy Storage System 2-5MWh

#### Features:

- Standard container design, system integration LFP battery, PCS, fire protection, intelligent temperature control as one, convenient transportation
- 1500V voltage level energy storage system, high energy density, advanced thermal management design, redundant fire protection design, battery active balancing technology
- Optimized system design and temperature control technology, low system loss, high safety
- With PQ, VF, VSG, SVG and black start function
- With high and low voltage crossing, fast power response, full reactive power compensation function, strong grid adaptability
- IP54 protection grade, strong adaptability to outdoor environment



### And Off-network Switching STS Module

300kW

#### Features:

- Three-phase five-wire system (3W+N+PE), support off-grid unbalanced load
- With PCS module, it can realize seamless switching and off-grid, ensuring uninterrupted power supply for important loads
- Modular design, easy installation and maintenance
- Module height is only 2U, compact structure, high power density

# BUSINESS AREA

## ONE

Power Station  
Development

## TWO

Commercial and  
Industrial Energy  
Storage System

## THREE

Residential  
Energy Storage  
System

## FOUR

Solar - Energy  
Storage - EV  
Charging Station

## FIVE

Microgrid

## SIX

Solar  
Pumping  
System



## 1. Power Station Development

Photovoltaic power station is a way to use the sun light energy through the photovoltaic battery light born v effect, convert solar radiation directly into electricity generating system. Photovoltaic power stations are mainly composed of solar cell arrays, inverters, transformers and other related auxiliary facilities, which are connected to the grid and deliver power to the grid. Photovoltaic power stations belong to green energy projects encouraged by the state.

### Key Benefits:

- Energy-saving construction
- Period is short
- Economic sustainability
- Can maintenance costs low
- Long service life
- Wide range of application

### Wide Cover

The power station covers government agencies, schools, hospitals, all kinds of industrial and commercial enterprises, as long as the energy consumption capacity is stable, photovoltaic power stations can be installed free of charge

### Zero Risk

Eliminate the burden of clean energy applications, no need for power enterprises to guarantee the duration of life, no commitment to electricity consumption, without any additional guarantees and responsibilities

### Individualization

Customized solutions according to the sunshine conditions and environmental characteristics of different regions, as well as the industrial needs of different companies, roof conditions, electricity characteristics and operations

### Distributed Power Plant Development

It refers to photovoltaic power generation facilities built near the user site, which are characterized by spontaneous self-use on the user side, excess electricity online, and balanced adjustment in the distribution system

### Centralized Power Plant Development

It refers to the centralized construction of photovoltaic power generation systems with installed capacity greater than or equal to 20 megawatts (MW) and grid-connected voltage above 35KV in a relatively large geographical area



## 2. Commercial and Industrial Energy Storage System

### Module design

- Standard interface, flexible group, reduce operation and maintenance costs
- Rapid deployment for large capacity jumps from kW to MW
- It can meet the multi-source access such as wind and light, and build the wind-light diesel engine storage micro-grid system

### Intelligent management

- Support data storage
- Computer side, mobile side real-time monitoring intelligent cloud management, remote operation and maintenance

### Efficient dynamic economic expansion

- Dynamic capacity increase to increase available capacity
- Provide new energy consumption, energy time shift, peak valley spread arbitrage, capacity electricity rate reduction and backup power use

### Safe and reliable

- Outdoor high protection level, in line with fire safety requirements, multi-layer safety protection design
- Supports anti-reverse flow and unbalanced three-phase output

Industrial and commercial energy storage refers to energy storage systems used in industrial or commercial terminals. From the perspective of end customers, energy storage can be divided into power supply side, power grid side and user-side energy storage, among which user-side energy storage includes industrial and commercial energy storage and household energy storage. The main purpose of industrial and commercial energy storage system is to use the peak-valley difference of the power grid to realize the return on investment, meet the internal power demand of industrial and commercial industry, and maximize photovoltaic power generation for self-use, or through the peak-valley price arbitrage.

## Plan 1 Energy Storage System

On the basis of the existing distribution, industrial and commercial energy storage systems are added to achieve accurate energy management and realize the backup function of important loads. In this scheme, the difference of electricity price between peak and valley period and reasonable arrangement of energy use time can obtain benefits.

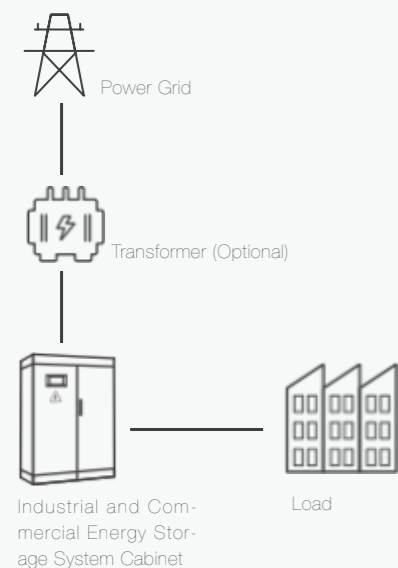

## Plan 2 Photovoltaic + Energy Storage System

On the basis of the existing distribution, the use of spare sites, generally industrial and commercial roofs, to add photovoltaic power generation systems, and then combined with industrial and commercial energy storage systems, to achieve photovoltaic new energy, source power supply, energy management, to achieve important load, backup functions. This case can not only obtain income through peak and valley power, price difference, but also obtain income through photovoltaic power generation and reduce power consumption of the grid.

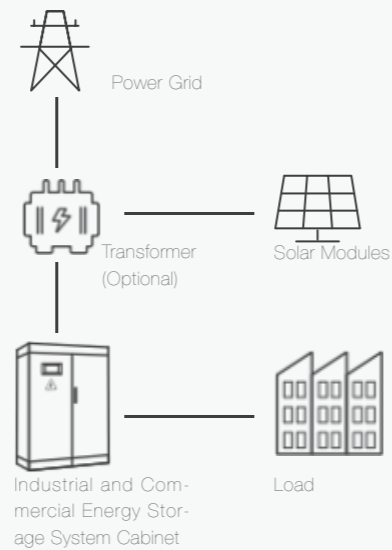

Industrial and commercial energy storage solutions integrate battery systems, energy management systems, PCS, intelligent temperature control systems, monitoring and alarm systems and other devices.

Suitable for peak cutting and valley filling, high-power grid expansion, industrial and commercial power backup, industrial and commercial power support, emergency power supply and charging pile expansion and other application scenarios.

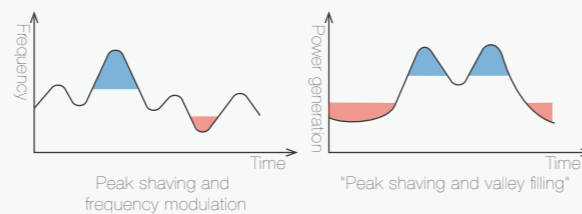

The system is suitable for sewage/water works, casting enterprises, mining enterprises, large fresh supermarkets, brand hotels and so on

Factories, enterprises, supermarkets, hotels, hospitals, gas stations, etc., provide safe and reliable medium power energy storage solutions, intelligent peak, safe and efficient, low carbon environmental protection, low investment and high income



## System Characteristics

- Solve industrial and commercial energy storage and power supply problems in the 50-500kWh range
- Intelligent, modular design, simple structure, easy to maintain, cabinet design, easy to install and use
- Integrated EMS for easy setup of peak and trough periods
- Safe and efficient, low carbon environmental protection, low investment, high return

## System Application Running Diagram

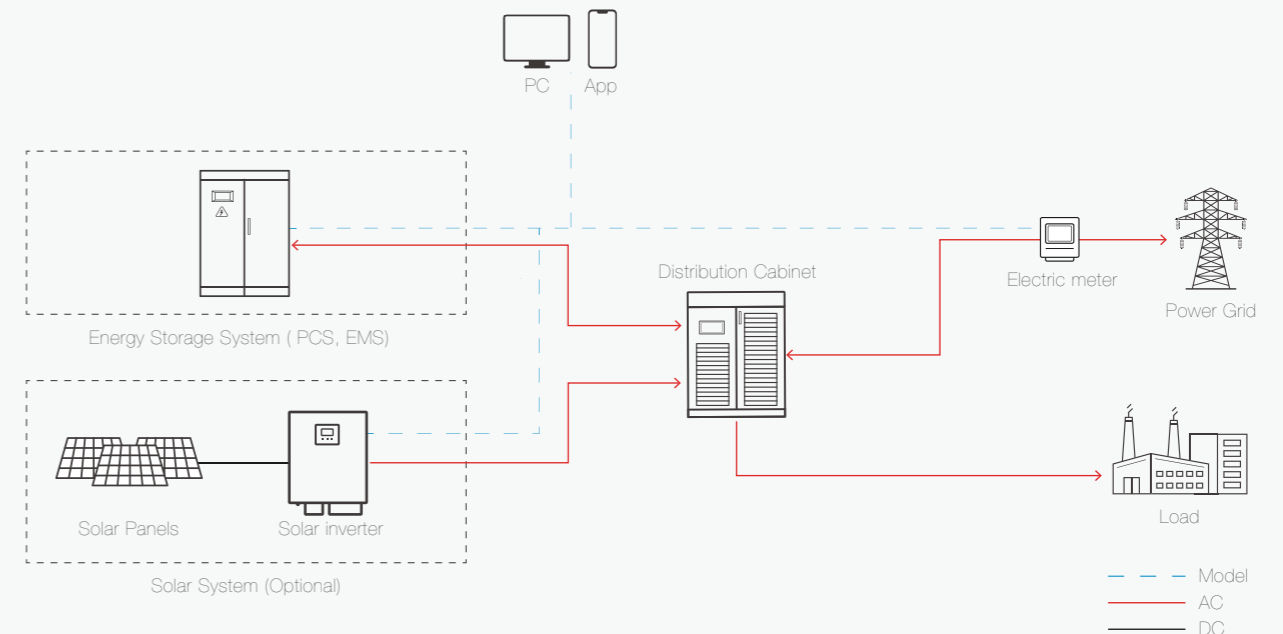



### 3. Residential Energy Storage System

Household energy storage refers to the energy storage system for household users, usually including batteries, supercapacitors and heat storage water tanks and other equipment, which can effectively store clean energy such as solar energy and wind energy produced by the family for emergency needs. Household energy storage systems are usually installed in combination with household photovoltaic systems to provide electrical energy for home users.

- Home light storage system, self-use, achieve energy independence, save electricity
  - Family backup power supply to ensure the safety of household electricity
  - Villa resorts, villages/communities, private homes or home power in areas without electricity
- 
- A set to solve the entire house electricity
  - 24 hours uninterupte power supply
  - The integrated design takes no space
  - Flexible battery capacity expansion
  - Remote monitoring is convenient and easy
  - Safe economy saves money and electricity



## Mobile APP/Web intelligent control

Mobile APP/PC real-time online quickly and comprehensively understand the project and equipment information. Through the software, you can easily understand the power generation, battery storage, online equipment, fault equipment, fault information, photovoltaic/energy storage output, charge and discharge data

## Battery intelligent management

To improve the utilization rate of the battery, the battery with BMS management system to prevent the battery out now overcharge and over discharge, prolong the service life of the battery cell and inverter USES the BMS communication, real-time monitoring of battery SOC, guarantee within a reasonable range, SOC found each battery SOC is not balanced, Changing inverter parameters can automatically balance battery power

- Long-term energy storage power supply applications
- Photovoltaic power supply + voltage regulation function for short time energy storage power supply applications
- Power safety guarantee

## Operation diagram

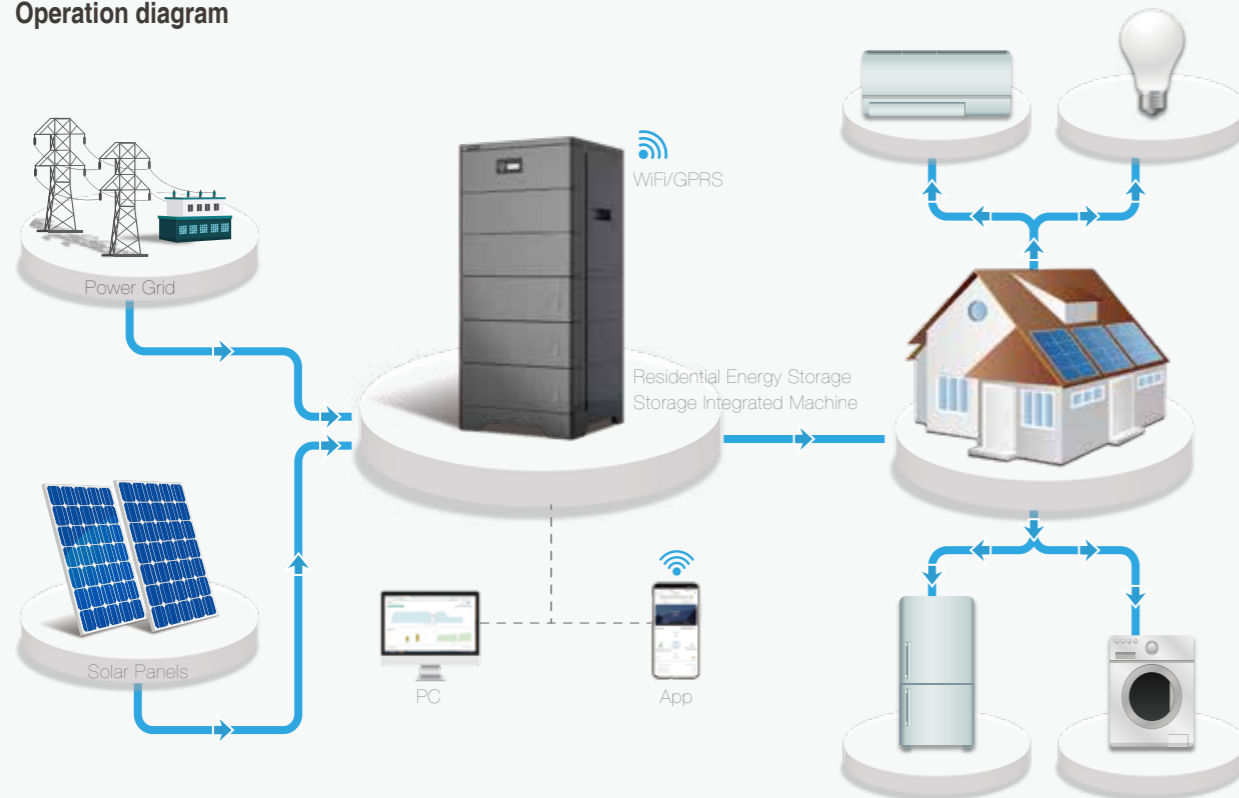

# Residential Energy Storage Products



**Battery Module – Rack Design**  
5.12kWh Lithium Battery (Rack Design)



**Battery Module – Rack Design**  
5.12kWh Lithium Battery (Rack Design)



**Wall-Mounted Battery**  
2.56/5.12/10.24kWh Lithium Battery



**Low-Voltage Mobile Batteries**  
14.3kWh Lithium Battery (Mobile Design)



**Solar Control Inverter Integrated Machine**  
1.2-11 kW Inverter



**Single Phase Hybrid Energy Storage Inverter**  
6 kW Hybrid Inverter



#### 4.Solar - Energy Storage - EV Charging Station

- The optical storage system has its own power supply
- Does not rely on the grid, the mains as a supplementary power supply
- Compared with traditional charging stations, it has independent pricing power and obvious market competitiveness
- Give play to its own products and technical advantages, flexible application
- Modular management, flexible response to market demand



## Optical Storage System



### Solar Power Generation System

Photovoltaic can be charged or stored to improve photovoltaic utilization



### Energy Storage System

The energy storage battery balances the charging load and reduces the distribution capacity requirement

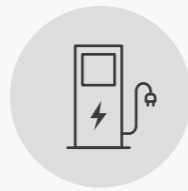

### Electric Vehicle Charging System

Improve the conversion efficiency between photovoltaic, energy storage and charging



### Energy Management System

Conducive to unified energy management

An optical storage and charge system is an energy system that integrates photovoltaic power generation, energy storage and charging facilities. It typically includes solar photovoltaic panels, energy storage batteries (such as lithium-ion batteries), and charging devices. Such systems can generate electricity from photovoltaic panels when the sun is shining and store excess power in batteries for use at night or on cloudy days. At the same time, the system can also provide charging services for devices such as electric vehicles.

### Advantages of optical storage and charge microgrid system



#### Solar Energy

- Improve the efficiency of idle roof or floor use
- It not only plays the role of heat insulation for the workshop, but also extends the service life of the roof
- Reduce the impact of peak power consumption, energy saving and emission reduction, beautify the environment

Absorb renewable energy, ease the load on the grid, and achieve zero carbon goals



#### Energy storage

- During peak power consumption, the optical storage system reduces the load of the power grid and achieves the effect of capacity expansion
- It has the function of peak cutting and valley filling and emergency power supply of yard station

Energy storage charge and discharge on demand, reducing demand electricity costs



#### Charging

- High power fast charging, to solve the problem of charging time
- Power and recharge, the whole network, no manual operation, convenient and fast
- According to demand, V2G reverse power supply can be achieved

### Principle of Solar Energy Storage and Charging Microgrid System

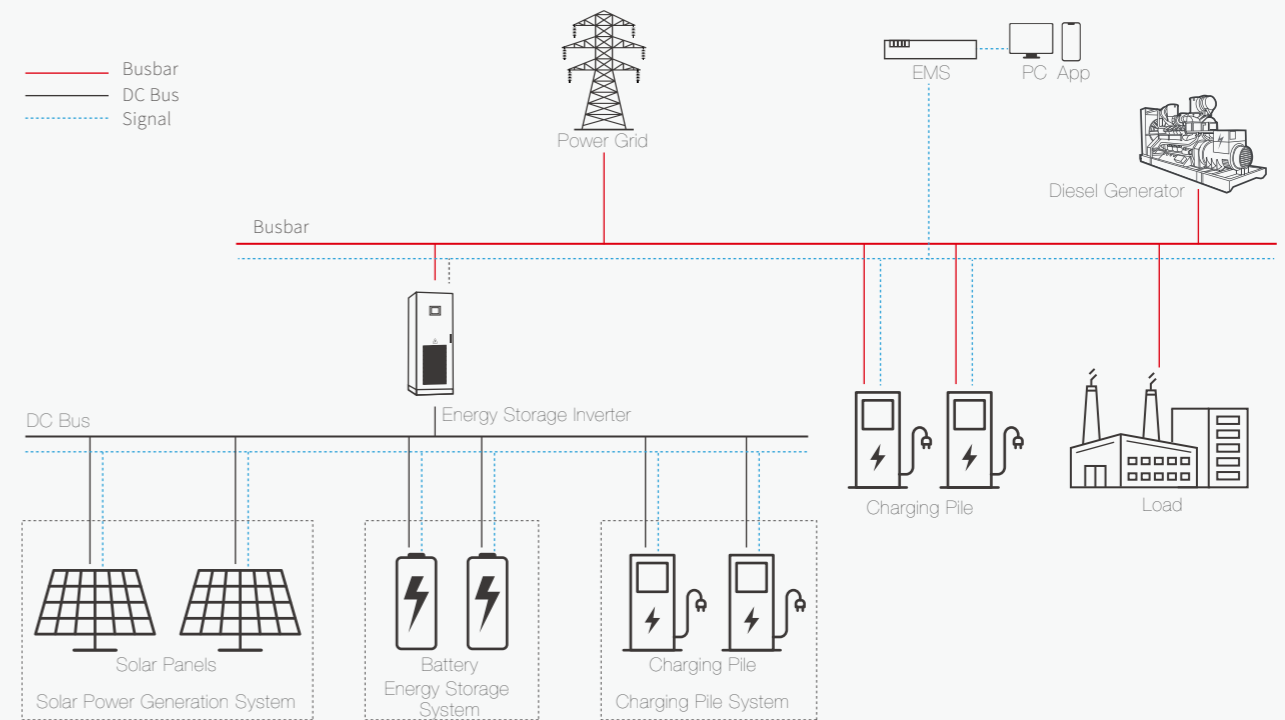

### Energy management system

- Perfect system data acquisition and monitoring functions
- Fast response to real-time alarms
- Seamless access to the dispatching center system, accept the charge and discharge control commands issued, and realize friendly data transmission between BMS and PCS devices
- Seamless switching of power supply units to achieve multi-energy complementarity
- Advanced control strategies are used to achieve peak valley arbitrage and reduce maximum demand





### Application scenario of optical storage and charge micro grid system

The optical storage, charging and discharge micro grid system can provide all-round and one-stop energy solutions for users in high-energy-consuming industries such as public office buildings, commercial complexes, industrial parks, residential areas, and highways

### Industrial Application Scenarios



Logistics Park



Steel mill



Mining area



Oil field

### Application Scenarios of Industrial and Commercial Parks



School



Hospital



Bank building



Government building



Camping base



Shopping mall supermarket



Commercial CBD

### Living Application Scenarios



Residential community



Private residence



Home solar storage and charging



Areas without electricity or with insufficient electricity



Village



Resort area

### Traffic Application Scenarios



Urban public charging stations



Highway service area



Wind-solar storage charging station



Port



Airport



Bus stop



## 5. Microgrid

Micro grid refers to the distribution of power sources (photovoltaic, wind A small power generation and distribution system composed of energy storage device, energy conversion device, load, monitoring and protection device, etc., is an autonomous system that can achieve self-control, protection and management according to pre-determined goals, and can be connected to the grid or independently operated. According to the current properties can be divided into: DC micro electricity Network, AC micro grid and hybrid micro grid



## Characteristics of Micro Grid Development

1. It is conducive to the local consumption of distributed new energy through relatively clear electrical materials. Self-balance and self-management modes are used to reduce the needs of system backup and regulation, and industrial and commercial micro grids use distributed new energy for self-use to reduce energy consumption costs.

2. Improve the level of electricity service in remote areas. In remote areas with "high sea and no electricity", such as high altitude, islands, border defense, and people without electricity, the geographical environment is complex, the load density is low, and the power supply is difficult. We will provide electricity to 490 million people without electricity.

3. Enhance power supply reliability and disaster resistance, and integrate multiple distributions within the micro grid. The power supply and energy storage device are seamlessly switched off from the grid, and the power supply for important loads is maintained for 2 hours when it is turned into an island operation. In the case of typhoons, earthquakes, mudslides and other disasters, the microgrid gives priority to ensuring the power supply safety of key institutions such as shelters and hospitals.

## Operation Principle of Micro Grid

The micro grid system uses photovoltaic and wind power generation to give priority to the load. The remaining power is stored in the energy storage device. When the power supplied by the photovoltaic and wind power is not enough to support the load, the energy storage system starts to supply power. If the photovoltaic, wind, and energy storage systems are not enough to support the load power, use the bypass mains or diesel generator set to supply power and charge the energy storage.

## Application Scenarios of Micro Grid Systems

Micro grid system is closely related to our production and life, and its application scenarios are many and wide, and it can be deeply integrated in agricultural life, industrial processing, business parks, enterprises and institutions, agricultural life, public transportation and communication industries. These include:

1. Photovoltaic water lifting system
2. Photovoltaic agricultural irrigation system
3. Oil production micro grid system
4. Communication base station micro grid system
5. Optical storage and charging micro grid system
6. Industrial and commercial optical storage micro grid system
7. Village-level power station micro grid system
8. Zero-carbon Park micro grid system
9. Mine restoration micro grid system
10. Island micro grid systems
11. Border posts.

## Schematic Diagram of Microgrid Operation Principles

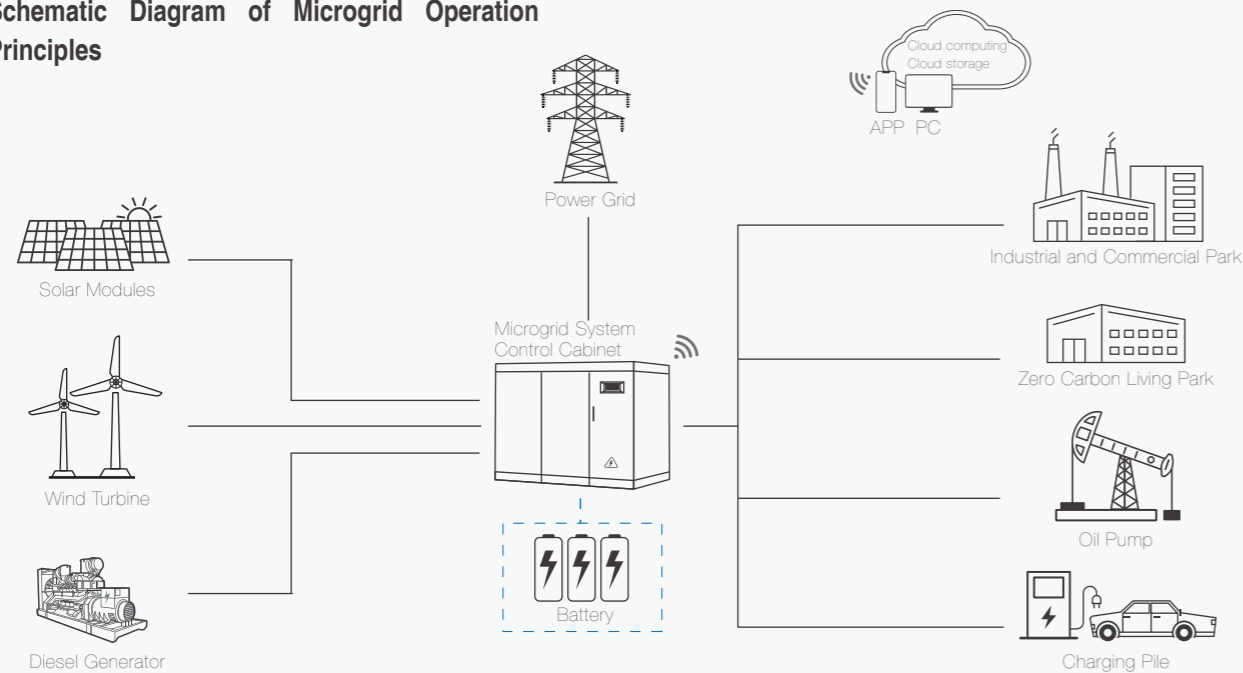

## Oil Extraction Application Scenarios



## Application Scenarios of Communication Base Stations



## Border Defense Outpost Application Scenarios



## Zero Carbon Living Park Application Scenarios





## 6.Solar Pumping System

### System Application

The photovoltaic pump system is mainly used in various projects in areas with good lighting and lack of water and electricity

- Water for pasture animal husbandry
- Agricultural irrigation
- Water supply in rural towns and villages
- Forestry irrigation
- Seawater desalination
- Desertification control
- ... ..
- Scenic fountain

### System Characteristics

- IP65 outdoor protection class
- We will address issues such as agricultural irrigation, daily water use, and desert management in areas without electricity or water shortages
- GPRS remote monitoring real-time operating status, real-time start and stop
- Compared with diesel generators, it has long life, high efficiency and short investment payback period
- Operating temperature range :-25°C-60°C
- Widely used in all kinds of photovoltaic modules and three-phase, single-phase AC pumps
- Excellent performance, 5% more water than peer inverters or systems in cloudy weather
- Fully automatic unattended operation, with perfect protection function



Photovoltaic intelligent irrigation system is composed of photovoltaic power generation system, photovoltaic variable frequency drive system, pump, head, filtration and water storage system, pressure and flow detection, solenoid valve and main branch pipe and other systems, fully driven by new energy, through photovoltaic direct drive technology, energy management technology and detection and control technology, combined with irrigation technology, The combination of photovoltaic power generation, automatic control and irrigation technology can be widely used in sprinkler irrigation and dropper systems in plains, hills and mountains, and the integrated green irrigation system of photovoltaic + irrigation is realized.

## Application Scenario

### In the Desert and The Gobi

Use low-lying terrain to collect and store water (anti-seepage), photovoltaic water lifting, Field irrigation area management, drip irrigation and micro-sprinkler irrigation and other methods.



### In the Hills

It adopts the methods of rainwater collection and storage, photovoltaic water lifting, distributed water storage on the top of the mountain, field irrigation area management, drip irrigation and micro-sprinkler irrigation.



### In the Plain

It adopts pond and ditch water storage, photovoltaic water lifting, field irrigation area management, drip irrigation and sprinkler irrigation.



## Application Scenario Diagram

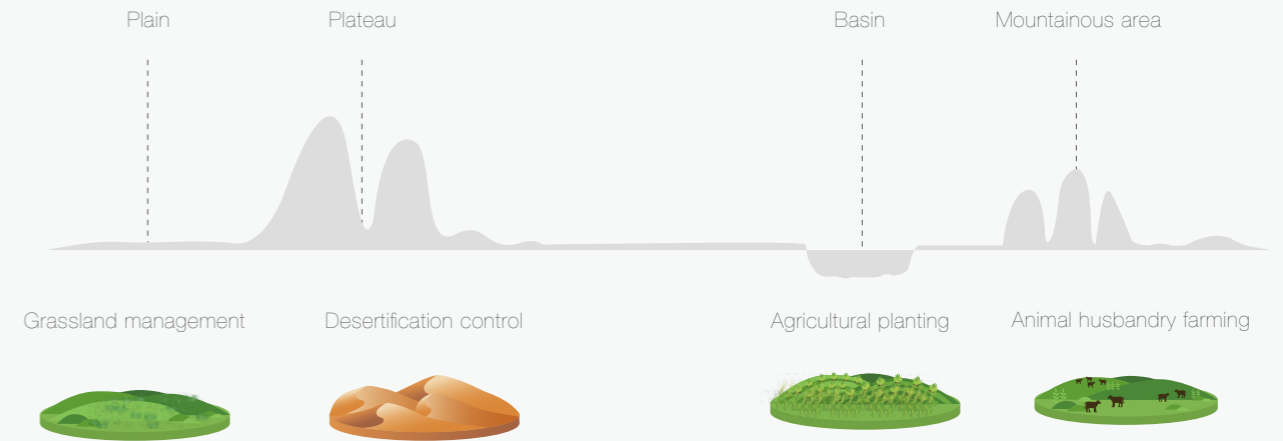

## Photovoltaic Pump System Introduction (AC System)

The photovoltaic pump system mainly consists of four parts: photovoltaic array, photovoltaic pump inverter, three-phase AC pump and water storage device. Photovoltaic array absorbs solar radiation energy, converts it into electrical energy, provides power supply for the entire system, photovoltaic pump inverter converts direct current output of photovoltaic array into alternating current and drives the pump, and adjusts the output voltage and frequency according to the change of sunshine intensity in real time to achieve maximum power point tracking. When the sunshine intensity is weak, the photovoltaic pump system can realize the mains switching function, and the mains acts as the supplementary energy of the photovoltaic pump system. Photovoltaic pump system has the concept of low carbon, energy saving and environmental protection, and can also significantly improve the living standards of people in areas with little water and electricity, so it will have broad market prospects and great social value.

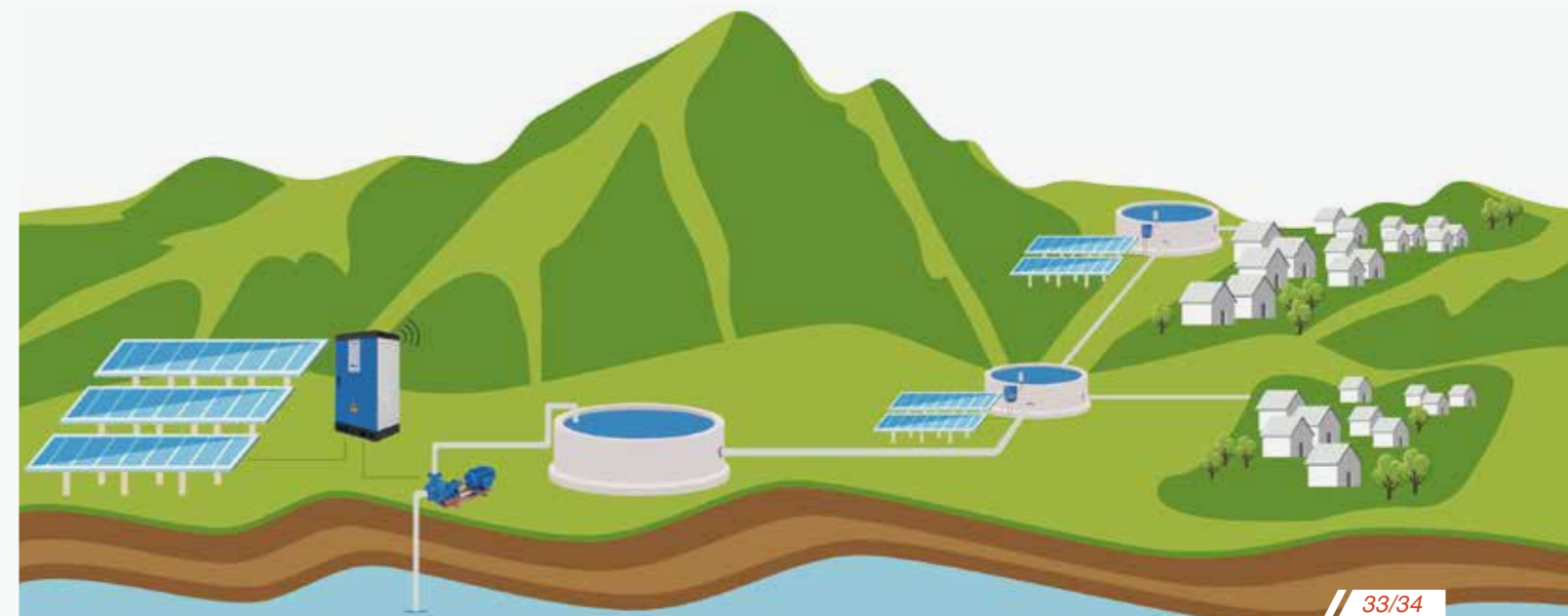



# PROJECT CASES

## 1. Power Station Development





# 1. Power Station Development Case

## Centralized Power Plant Development



Three Gorges New Energy Hami 20MW power station project



Golmud, Qinghai 5MW photovoltaic power station project



Yingshang County Jiaogang Lake 60MW ecological agriculture photovoltaic power generation project



Xinjiang Atushi 60MW power station project



20MWp fish-light complementary grid-connected photovoltaic power station in Shengli Wei District, Lujiang County



Lujiang County White Lake Farm 20MWp user side grid-connected power generation system project

## Distributed Power Plant Development



Chery roof 13MW power station in Wuhu



9.5MW power station on the roof of Hitachi Station



## 2. Commercial and Industrial Energy Storage System

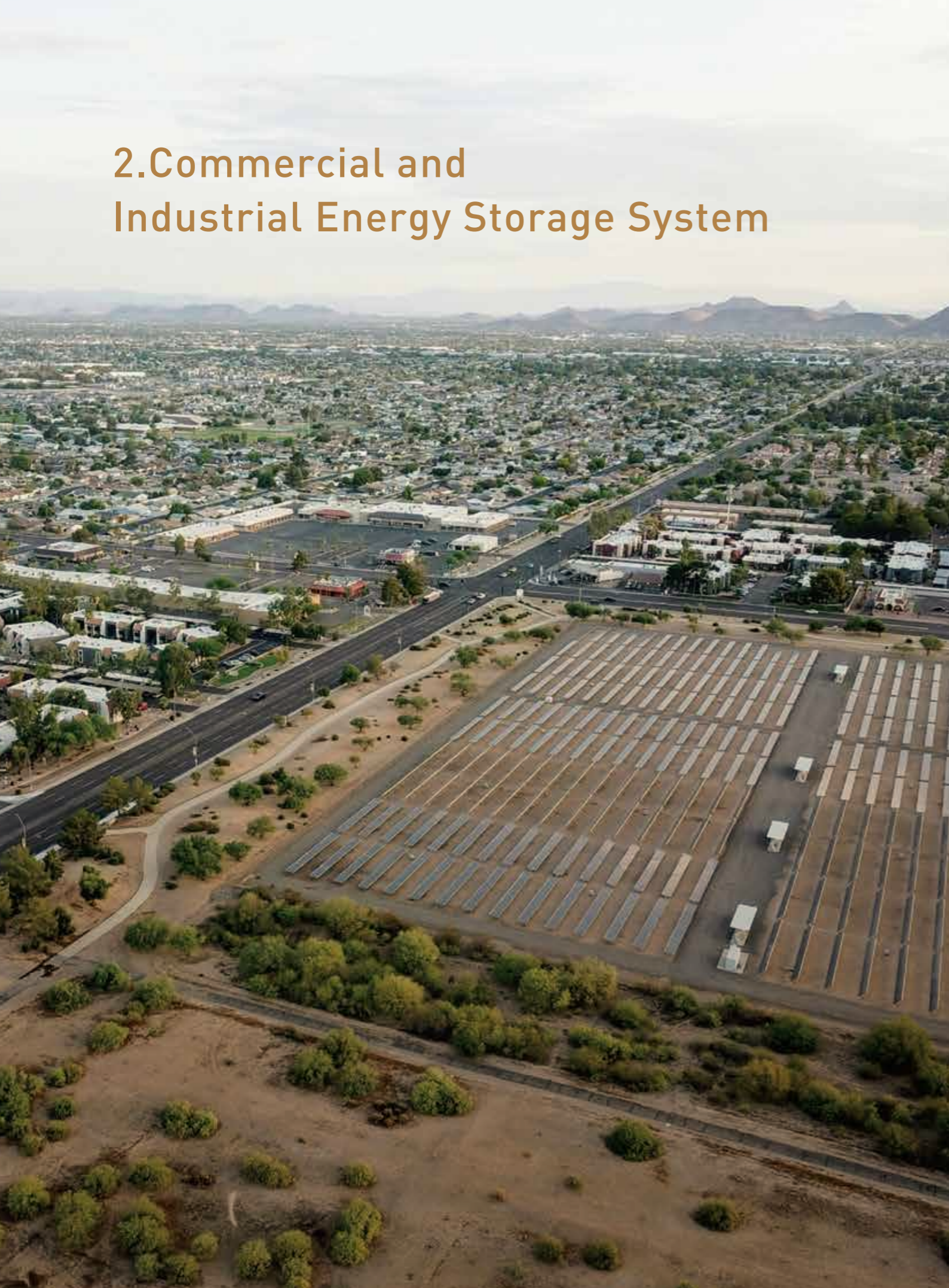

Qinghai State grid 15kVA wind and scenery complementary project



Hefei 100kW/200kWh energy storage system



Botswana energy storage system project



### 3. Residential Energy Storage System



Anhui 5kVA photovoltaic energy storage system



Six 10kVA photovoltaic energy storage systems in the Philippines



Cambodia 5kVA photovoltaic off-grid system



Cambodia 4kW-2kVA hybrid system



Jiangsu Wuxi 5kw project



Shijiazhuang, Hebei 10kw project



# 4.Solar - Energy Storage - EV Charging Station



Bus optical storage charging power station project



Las Vegas Scenery Storage and Charging Power Station Project (under construction)



Hefei light storage charging power station project



# 5. Microgrid







Xinjiang oilfield oil extractor micro-grid demonstration project



Xinjiang Korla region China Mobile base station project



Direct drive system of Xinjiang oilfield



Congo Chaiguang storage microgrid system



Beijing Ministry of Science and Technology distributed power generation system demonstration project



Zero Carbon Living Park Demonstration Project



Qinghai State grid Balong relay station wind-wind complementary project



Qinghai State Grid Tuotuo River relay station wind-wind complementary project



# 6.Solar Pumping System



1.2MW Baihetan hydropower station photovoltaic multistage pumping station



Xuanwei City Xiaojiang photovoltaic water lifting project



Africa · Zimbabwe  
168kWp full photovoltaic direct drive high-power intelligent sprinkler irrigation system



Africa · Zimbabwe  
1.144MWp Wanjin photovoltaic power generation water lifting irrigation project





## JNTech Renewable Energy

### One-stop service is more flexible and less worrying

- In-depth research and analysis;
- Select the best site address according to the specific requirements of the project;
- Targeted to customer needs;
- Systematic design of optimal solutions.

## PARTNERS

