



# 872

## 连续制板用合股无捻粗纱 Assembled Roving for Panel

### 产品说明 Product Description

872 是连续板材成型工艺用合股无捻粗纱，表面涂覆硅烷基浸润剂。适用于增强不饱和聚酯树脂与亚克力树脂等。

872 产品具有极快速的浸透性，与不饱和树脂匹配性好，适合生产对透明度要求苛刻的 FRP 板材。

*872 Assembled Panel Roving is coated with a silane-based sizing compatible with unsaturated polyester and acrylic resins.*

*872 delivers extremely fast wet-out and a good bonding with unsaturated resins, which make it ideal for use in panel applications where high transparency is critically required.*



### 产品特点 Product Features

- ◎ 良好的短切性
- ◎ 一定张力条件下，纱束分散性好
- ◎ 良好的树脂折光率匹配性，极快速的浸透性
- ◎ 制品具有优良的机械强度
- Good choppability
- Good dispersion under certain tension
- Good resin refractive match and extremely fast wet-out
- Excellent mechanical properties of parts

### 规格代号 Specification

玻璃类型 Glass type	E
浸润剂类型 Sizing type	硅烷 Silane
典型纤维直径 Typical filament diameter (μm)	12
典型线密度 Typical linear density (tex)	2400
示例 Example	ER12-2400-872

### 技术指标 Technical Parameters

项目 Item	线密度偏差 Linear density variation	含水率 Moisture content	可燃物含量 Sizing content	硬挺度 Stiffness
单位 Unit	%	%	%	mm
检测方法 Test method	ISO 1889	ISO 3344	ISO 1887	ISO 3375
指标 Standard range	± 4	≤ 0.07	0.60 ± 0.15	115 ± 20

### 使用说明 Instructions

- ◎ 本产品可在6个月内使用最佳，使用前应保存在原包装内。
- ◎ 产品使用时注意防护，避免产品擦毛、损伤等情况。
- ◎ 使用前调理纱线的温湿度与环境温湿度平衡，同时建议使用温度控制在5°C ~ 30°C。
- ◎ 使用时请合理控制张力并保证张力均匀性。
- ◎ 刀辊、皮辊做好定期保养。
- The product is best used within 6 months after production, and should be kept in the original package before use.
- Care should be taken when using the product to prevent it from being scratched or damaged.
- The temperature and humidity of the product should be conditioned to be close or equal to the ambient temperature and humidity respectively before use, and the temperature when the product is used is preferably in a range from 5°C to 30°C.
- When using the product, please control the tension properly and ensure the tension uniformity.
- The cutter rollers and rubber rollers should be maintained regularly.



# 872

## 连续制板用合股无捻粗纱 Assembled Roving for Panel

### 包装信息 Packaging

项目Item	单位unit	指标Standard			
典型包装方式 Typical packaging method	/	采用托盘包装 Packed on pallets.			
典型纱团高度 Typical package height	mm (in)	260 (10.2)			
纱团内径 Package inner diameter	mm (in)	100 (3.9)			
典型纱团外径 Typical package outer diameter	mm (in)	280 (11.0)		310 (12.2)	
典型纱团重量 Typical package weight	kg (lb)	17.5 (37.5)		23 (50.7)	
层数 Number of layers	层 (layer)	3	4	3	4
每层纱团个数 Number of packages per layer	个 (pcs)	16		12	
每托纱团个数 Number of packages per pallet	个 (pcs)	48	64	36	48
每托重量 Net weight per pallet	kg (lb)	840 (1851.9)	1120 (2469.2)	828 (1825.4)	1104 (2433.9)
托盘长度 Pallet length	mm (in)	1140 (44.9)		1270 (50.0)	
托盘宽度 Pallet width	mm (in)	1140 (44.9)		960 (37.8)	
托盘高度 Pallet height	mm (in)	940 (37.0)	1200 (47.2)	940 (37.0)	1200 (47.2)

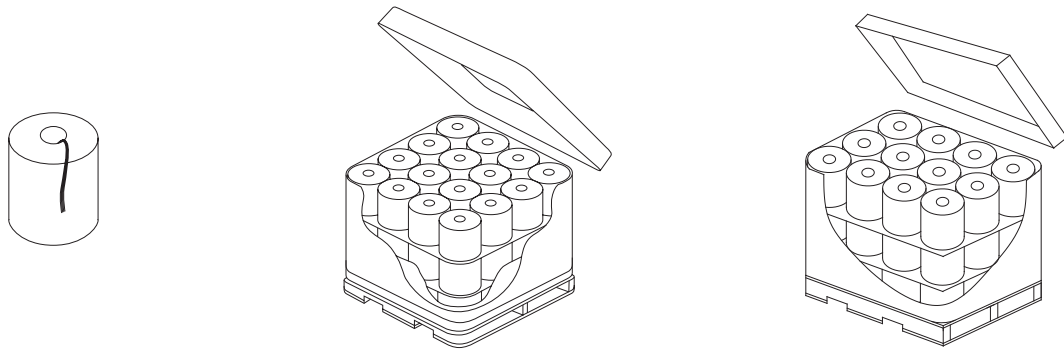

### 贮存 Storage

在没有特殊要求的情况下，玻璃纤维产品应贮存在干燥、阴凉的地方，防止受潮。最佳存储条件为温度 -10°C ~ 35°C，相对湿度≤80%。为确保安全，避免损坏产品，托盘的堆码高度不应超过三层。当堆放两层或三层高时，要求正确地、平稳地移动上面的托盘。

Unless otherwise specified, the fiberglass products should be stored in a dry, cool and moisture-proof area. The best temperature and humidity should be maintained at -10°C~35°C and ≤80% respectively. To ensure safety and avoid damage to the product, the pallets should be stacked not more than three layers high. When the pallets are stacked in two or three layers, special care should be taken to correctly and smoothly move the upper pallet.

安徽天复新材料有限公司 ANHUI TIANFU NEW MATERIAL CO.,LTD

Copyright 2024 安徽天复新材料有限公司

Add: Room 1716, Lvdi Building, Qianshan Road, Zhengwu District, Hefei City, Anhui Province, China

Tel/WhatsApp/Skype: +86 13696771864

Email: sales@tfcomposite.com

Website: www.tfcomposite.com